

POLK COUNTY

DEPARTMENT OF PUBLIC WORKS

ROAD STANDARDS

The Polk County Board of Commissioners
Adopted These Standards on July 22, 1998

These standards prepared by and under
the auspices of the staff of the
Public Works Department

TABLE OF CONTENTS

<u>Section</u>	<u>Page</u>
I. Introduction.....	1
II. Application.....	1
III. Definitions.....	1
IV. Functional Classification	4
V. Project Types	5
VI. Access To A County Road.....	6
VII. Public Use Roads.....	10
VIII. Private Roads	11
IX. Use Of County Right-of-Way By Others	13
X. Transportation Impact Analysis	14
XI. Roadway Design Standards.....	22
XII. Pavement Design Standards.....	33
XIII. Drainage Standards.....	35
XIV. Structural Standards.....	47
XV. Construction Standards.....	47
XVI. Roadway Delineation	47
XVII. Exception Process for Roadway Design Standards.....	52
XVIII. Construction Plans	53
XIX. Reference Standards	57
Appendix 1 Checklist for Subdivision Review.....	59
Appendix 2 Checklist for Engineering Plan Review	61
<u>Section</u>	<u>Page</u>

Appendix 3	Checklist for Transportation Impact Analysis Review	65
Appendix 4	Standard Drawings.....	66

LIST OF TABLES

<u>Table Number</u>	<u>Table Description</u>	<u>Page</u>
1	State Highway Access Distance	9
2	Driveway Dimensions.....	9
3	Roadway Width and Surfacing.....	11
4	Right-of-Way Widths.....	11
5	Transportation Impact Analysis Horizon Year Requirements	16
6	Rural Geometric Design Standards	24
7	Urban Geometric Design Standards	25
8	Cul-de-Sac Design Standards	26
9	Turning Radii at Intersections.....	27
10	Stopping Sight Distances	28
11	Design Controls for Horizontal	30
12	Design Controls for Vertical.....	31
13	Pavement and Aggregate Structural Standards.....	34
14	Paving Requirements for New Roads	34
15	Tongue and Grooved Pipe on Curved Alignment	37
16	Catch Basin and Curb Inlet Capacities.....	43
17	Area Drain Capacities	43
18	Design Storm Frequency.....	44
19	Composite Runoff Coefficients	44
20	Characteristic Runoff Coefficients	45
21	Overland Flow Travel Time	45

<u>Table Number</u>	<u>Table Description</u>	<u>Page</u>
22	Delineator Warrants	51
23	Delineator Spacing on Horizontal Curves.....	51

I. INTRODUCTION

The purpose of the Polk County Road Standards is to establish the general guidelines and minimum standards for the design and construction of new roadway facilities and major improvements to existing roads improved by development within the jurisdiction of Polk County. These standards are intended to be utilized as a working document that shall be revised and updated periodically; for example, the conversion to the metric system will necessitate a revision. The Polk County Public Works Department has separate standards and requirements for maintenance of County roads.

The primary objective of road standards is to ensure safe, usable, and economical roadway facilities for the citizens and businesses of Polk County.

These standards shall apply to new facilities. Existing and reconstructed facilities shall be brought up to these standards in accordance with the county road system needs based on direction from the Board of Commissioners, and the availability of funds.

Interpretation and enforcement of these standards shall be the responsibility of the Public Works Department and the Board of Commissioners.

II. APPLICATION

The standards shall apply to, but are not limited to, the following items:

A. The design of roads, streets, and appurtenances within county right-of-ways and roadways under county jurisdiction.

B. New construction of roadway facilities within county right-of-ways.

C. The design of new drainage facilities and appurtenances within and affecting county right-of-ways and roadways under county jurisdiction.

D. Polk County Ordinance requirements concerning subdivisions, partitions, and any other industrial, commercial, or community development involving roadway facilities that affect county roadways and right-of-ways.

III. DEFINITIONS

Access – The connection of any existing or proposed road or bike related facility to a county road, examples include development of a private driveway or a private or public road.

ADT - Average Daily Traffic. The total number of vehicles traveling in both directions in a 24-hour period.

AASHTO - American Association of State and Highway Transportation Officials. Provides design criteria for road and street construction within the United States.

Arterial - A roadway intended to carry large volumes of traffic (typically 1,000 ADT or more) outside of an Urban Growth Boundary (UGB) and connect major traffic generators, cities, recreational areas, and major segments of transportation networks. High capacity is achieved through allowing higher speed, limited access, wider roadway and movement preference at intersections with lesser standard roadways.

Principal Arterials are major urban and rural highways connecting communities, towns, and cities. The principal arterial provides for through traffic movement and distribution to lower order roadways.

Minor Arterials connect areas of principal traffic generation to major urban and rural highways. The minor arterial network provides for through traffic movement to the major arterials and distribution into the network of collector and local streets.

Bridge - A structure built for the purpose of traversing another structure(s), or a river, creek, stream, canyon, swale, or ditch.

Collector - A roadway intended to carry intermediate volumes of traffic (typically 500-1,500 ADT outside of an urban growth boundary) and collect and distribute traffic from local streets to arterial, state highways or small population centers.

Major Collectors carry local traffic between neighborhood areas to arterial facilities. The major collector provides access from minor collectors to community services and to other neighborhoods within, or immediately adjacent to, urban areas.

Minor Collectors serve as links between the local street system and the higher order roadways. Minor collectors carry traffic between minor traffic generators, such as neighborhood shopping and community centers and schools.

Resource Collectors provide a connection between resource areas (farm, forest, mineral and aggregate), and principal and minor arterials. These roadways are generally rural and provide access to agricultural and timber roadways, to facilitate movement of goods and services.

Construction Agent - Any private or public organization or individual that proposes to repair, improve or construct a roadway, drainage facility, or any other type structure within a county right-of-way.

Conveyance System - Catch basins, inlets, manholes, pipes, culverts, ditches, ditch inlets, or other facilities that carry runoff.

County Road - A public road under the jurisdiction of the county that has been designated as a county road through an order by the Board of Commissioners pursuant to Oregon Administrative Rule (OAR) Chapter 368. Typically, this designation causes the roadway to be maintained by the county.

Cul-de-sac - A turnaround at the end of a dead-end street or road.

Culvert - A conduit or pipe placed within a right-of-way for the purpose of conveying surface drainage water from a river, creek, stream, swale, ditch, or intermittent water conveyance.

Design Speed - The minimum design speed for each classification of road as shown in Tables 5 and 6. The design speed can be the 85 percentile speed unless the road improvement will increase the 85 percentile speed.

Ditch - A man-made excavation in the earth used to convey drainage or irrigation water.

Drainage Facilities - The physical element used to convey, absorb or store runoff such as pipes or channels, dry wells, and detention or retention ponds.

Easement - The grant of a right of use across or through an area or tract of land for specific or general purposes.

Engineer - A registered professional civil engineer licensed by the State of Oregon.

Highway - A major roadway having the connotation of being owned and maintained by the State of Oregon.

Local Road or Street - A roadway serving short distance, intra-neighborhood and residential needs. These roads support a minimum traffic carrying capacity, but provide maximum access to adjacent property.

Local Access Road - A public road dedicated for use by the public and within public right-of-way, but not maintained by the county. The roadway is maintained by the adjoining or using property owners except as directed by the Board of Commissioners. Also referred to as a public use road.

ODOT - Oregon Department of Transportation. Provides information and guidance on design and construction of roads within the State of Oregon.

Pre-development - A site with natural vegetation on native soil.

Private Road - A road which is on private property and maintained by private funds.

Public Right-of-Way (R/W) - A right-of-way on which legal right of passage has been given to the public and is under city, county, state or federal jurisdiction.

Reverse Frontage Lot - A lot having frontage on two parallel or approximately parallel roads, where the rear of the lot, or structure on the lot faces an arterial.

Right-of-Way - A legal right of passage over a piece of land, generally established by either an easement (resolution) or ownership (dedicated/deeded).

Road - A roadway generally having the connotation of serving rural areas. Some roads, however, are located in urban areas, particularly between the corporate limits of a city and the adopted UGB.

Roadway - The general term used to describe the strip of land, structures, surfacing, and shoulders over which motorized vehicles travel. The roadway includes the area between the edges of shoulder or curb and the area two feet beyond the edge of shoulder or curb.

Rural - Those areas within Polk County which lie outside an adopted Urban Growth Boundary (UGB).

Storm Water Runoff System - A means to control storm water through natural or man-made elements by conveyance, absorption or storage.

Street - A roadway having the connotation of serving urban or city needs. Streets are most often located within the corporate limits of a city.

Transportation Impact Analysis (TIA) - A study which evaluates the adequacy of the existing transportation system to serve a proposed development and the expected effects of the proposed development on the transportation system. A TIA is required when a particular development is expected to generate more than more than 300 vehicle trips during a single day and/or more than 100 vehicle trips during a single hour. The TIA should provide adequate information for Public Works to evaluate the development proposal and, if necessary, identify traffic mitigation measures.

Urban - Those areas of Polk County which lie within an adopted Urban Growth Boundary (UGB).

Urban Growth Boundary (UGB) - An adopted city and county boundary which includes the estimated supply of various land types (commercial, industrial, public, and residential) intended to serve the city's needs over a 20-year planning period.

Utilities - Any water, gas, sanitary or storm sewer, electrical, telephone, television, drainage, cable, or communication service.

Walkways - A transportation facility built for use by pedestrians, including persons in wheelchairs. Walkways include sidewalks, paths, and paved shoulders.

IV. FUNCTIONAL CLASSIFICATION

The classification of each roadway in the county road system shall be based on the function it serves at present and its anticipated function in the future. These functional classifications are as follows:

A. **Principal Arterials** are major urban and rural highways connecting communities, towns, and cities. The principal arterial provides for through traffic movement and distribution to lower order roadways. Direct access to abutting properties shall be limited and controlled. On roadway parking shall, in general, be prohibited. Principal arterial roadways fall primarily under state highway jurisdiction.

B. **Minor Arterials** connect areas of principal traffic generation to major urban and rural highways. The minor arterial network provides for through traffic movement to the major arterials

and distribution into the network of collector and local streets. Arterials are subject to regulation and control of parking, turning movements, and access to abutting properties.

C. Major Collectors carry local traffic between neighborhood areas to arterial facilities. The major collector provides access from minor collectors to community services and to other neighborhoods within, or immediately adjacent to, urban areas. Major collectors may have controlled access to abutting property and controlled parking.

D. Minor Collectors serve as links between the local street system and the higher order roadways. Minor collectors carry traffic between minor traffic generators, such as neighborhood shopping and community centers and schools. Minor collectors may have controlled parking and controlled access to abutting property (see Standard Drawing 0033).

E. Resource Roads provide a connection between resource areas, and principal and minor arterials. These roadways are generally rural and provide access to agricultural and timber roadways, to facilitate movement of goods and services. Resource roads provide an important and needed function in serving areas that contribute to the economic base of the community even though they may have low volumes of traffic.

F. Local Roads and Streets provide direct access to abutting property. Through traffic will be discouraged on local streets. Curb-side parking will be permitted on streets that have a 34 foot wide roadway (see Standard Drawings 0007 and 0040). In urban areas, parking along local roads may be permitted if there is a 7 foot wide parking strip located beyond the shoulder (see Standard Drawing 0040).

The terms “urban” and “rural” are used in conjunction with functional classification designations to denote the location of roads relative to an adopted Urban Growth Boundary (UGB). For example, the portion of a minor collector road lying inside a UGB would be designated as an Urban Minor Collector in the County’s Road Inventory. The portion of such a road lying outside of a UGB would be designated as a Rural Minor Collector.

V. PROJECT TYPES

A. New Construction projects involve construction of roadway facilities in a new location. This may include new alignments, intersections, rebuilding an existing facility with major vertical or horizontal alignment changes, or replacing a major structure. A construction permit must be obtained from the Public Works Department prior to the commencement of new construction.

B. Reconstruction projects upgrade an existing facility to acceptable geometric standards. Improvements include minor structure replacements, subgrade reconstruction, intersection and sight distance improvements, major widening, minor vertical or horizontal alignment changes, and the addition of travel lanes. These types of projects may be undertaken by County staff, construction contractors, or a combination thereof. A construction permit must be obtained from the Public Works Department prior to the commencement of any reconstruction project.

VI. ACCESS TO A COUNTY ROAD

Access means the connection of any existing or proposed road or bike related facility to a county road; for example, development of a private driveway or a private or public road. First and foremost, an access shall be safe and shall not create a road hazard for vehicles traveling a county road. In addition, an access shall conform to the requirements listed below and, when specified by the County Engineer, conform to the intersection standards listed in the Roadway Design section paragraphs M and N. Prior to issuance of a Road Access Permit, a Transportation Impact Analysis (TIA) may be required as described in Section X. If necessary, the TIA shall describe mitigation required to offset the impacts of development on the county road system.

A. Access and Construction Permits - Prior to constructing a new access, widening an existing access or changing the use of an access, a Road Access permit shall be obtained from the Public Works Department. A permit fee shall be paid at the time of application for access construction permit. The permit shall normally have an attached standard drawing and conditions which describe the minimum requirements of the access. A construction permit will be issued concurrently by Public Works when establishing access includes constructing, widening, or otherwise modifying an access.

No fee shall be required for a permit in the following circumstances:

- 1) Where installation of public facilities by public or quasi-public entities is involved; or
- 2) In any instance where the Board of Commissioners deems it to be in the best interests of the County to waive the permit fee.

B. Location and Number of Access Points - Access on to county roads shall be provided in a manner and location that shall protect public safety. The number of access points on to a county road shall be held to the minimum necessary to provide adequate connection to a lot or parcel. Unless otherwise specified by the County Engineer, the maximum number of driveway access points is as follows:

Urban Areas (within an Urban Growth Boundary) - One access point per lot or parcel. No more than 40 percent of the roadway frontage of a lot or parcel shall be devoted to accesses. This standard does not apply to “flag” lots or parcels or lots or parcels located on a cul-de-sac which have less than 50 feet of road frontage.

Rural Areas (outside an Urban Growth Boundary) - Two access points per lot or parcel (Additional access points may be allowed by the Public Works Director).

The location of access points shall meet the following standards:

- 1) No access shall be allowed where there is less than the minimum stopping sight distance as specified in Table 10, unless otherwise specified by the County Engineer. The sight distance shall be measured in the same manner as for intersections except that the driver's eye (point of measurement) shall be located a minimum 10 feet behind the face of the curb or, edge of the traffic lane. The driver's eye is located 3.5 feet above the ground.
- 2) The access shall intersect a county road at or as near a 90 degree angle as is practical. In no case shall it be less than 60 degrees from horizontal (see Standard Drawing 0020).
- 3) Where there are several adjacent parcels with narrow frontage or where sight distance is inadequate, a frontage road (or easement) or combined access may be required.
- 4) Where two (2) or more parcels are created by partition, one (1) common access shall be preferred.
- 5) Where property is located at an intersection of an arterial or collector and a local road/street, the preferred access shall be on the local road/street.
- 6) On a corner lot, no portion of any access shall be allowed within the curb return or pavement/gravel flare of the intersection. On collectors, it shall be a minimum of 30 feet from the end of the curb return or, if there is no curb, from the end of the pavement/gravel flare. On arterials, it shall be a minimum of 75 feet from the end of the curb return or, if there is no curb, from the end of the pavement/gravel flare.
- 7) Along curbed streets, no portion of any access including taper, flare, transition, or apron shall be allowed within three (3) feet of an adjacent property line unless it is an approved joint use access.
- 8) Along non-curbed roads/streets, no portion of any access including culvert or backfill material shall be allowed within 5 feet of an adjacent property line (unless it is an approved joint use access), a utility structure such as a power pole, or a roadway structure such as a cross culvert or guardrail.
- 9) No portion of any access shall be allowed within 50 feet of a bridge or bridge guardrail.

C. Access Onto Arterials

- 1) The number of access points onto arterial roads from any development shall be minimized whenever possible through the use of driveways common to more than one development, and interior circulation design, including frontage or marginal access roads, which further this requirement. Approach road permits for access onto state highways must be obtained from the Oregon Department of Transportation (ODOT) (this is provided as information only). Generally, no driveway, or County or public road access will be permitted onto the rural portions of State Highways 18, 22, 51, 99W, 221, and 223 unless the standards shown in Table 1 are met.

**Table 1
State Highway Access Distance**

Access Type	Distance from Nearest Access Point					
	Hwy 18	Hwy 22	Hwy 51	Hwy 99W	Hwy 221	Hwy 223
Driveway	1,200 feet ¹	1,200 feet	500 feet	1,200 feet	500 feet	300 feet
County or Public Use Road	1-3 miles	1 mile	.5 mile	1 mile	.5 mile	.25 mile

Source: Oregon Department of Transportation

¹ Right turn only access permitted

2) Where property, such as a reverse frontage lot, is located abutting a county or public use road, and a state highway, the preferred access will be onto the county or public use road.

3) Within an adopted UGB, the location and spacing of access points onto designated arterials shall conform to the standards of the affected city.

D. Widths - Access width shall be as specified on the standard drawing attached to the permit. General guidelines for driveway widths are shown in Table 2 and Standard Drawings 0015 and 0016. Specific width and flare radii are based on the anticipated traffic.

**Table 2
Driveway Dimensions**

Road	Width (feet)	Flare Radius (feet)	Angle of Intersection
RURAL			
Residential	20-24	10-20	90
Commercial/Farm	20-35	20-30	90
URBAN			
Residential	12-24	10-20	90
Commercial	20-40	20-35	90

E. Surfacing - Driveway surfacing within the County right-of-way shall be as specified on the standard drawing attached to the permit.

1) All commercial and industrial driveways shall be paved to standards set by the County Engineer on a site specific basis so as to support the anticipated traffic. A 30-foot minimum paved apron is required where a commercial or industrial driveway intersects a paved road. The County Engineer may waive the paving requirement if an unpaved driveway does not result in an unsafe condition for the anticipated traffic.

2) Residential accesses shall have a minimum surface of 6 inches of 1 inch-0 crushed rock. Where they are to be paved, the minimum surface shall be 2 inches of asphalt concrete over 6 inches of 1 inch-0 crushed rock. The County Engineer may specify a paved access to mitigate safety concerns for sight distance and grade. The paved portion of the access shall extend from the edge of pavement on the county road to the property line.

F. Slopes - Slopes of accesses shall not exceed 12 percent unless otherwise specified by the County Engineer. In addition, the access shall slope away from the county road at a grade not to exceed 2 to 2.5 percent beginning at the edge of shoulder and continuing for a distance of 5 feet. This area is referred to as a Safe Stopping Area.

G. Drainage Requirements - Within public right-of-ways, where there are no curbs, there shall be culverts placed under accesses if specified in the permit. The location, length and size of the culvert shall also be specified in the permit. The types of culvert pipes that are allowed are concrete, corrugated metal or corrugated polyethylene (ADS N-12), or similar materials.

H. Owner Responsibility - It is the responsibility of the owner of the access to keep any culverts and ditches on private property clean so that water does not pond near or flow on to a county road. An owner shall repair an unsafe condition as soon as possible after notification (in writing) by the Department of Public Works. If after proper notification and time the owner has not repaired an unsafe condition, the County shall make the required repairs at owner expense.

I. County Responsibility - The County is responsible for replacing an access, including culvert, at county expense if the access must be relocated as part of a county road project.

VII. PUBLIC USE ROADS

The construction and maintenance of a public use road(s) shall remain the responsibility of the applicant or adjacent property owners until such time as the road has been improved to either a Local Road standard or Minor Collector standard (either may include a paving requirement) and accepted as part of the Polk County Road System by the Board of Commissioners. See Standard Drawing 0005 for the typical section of a public use road. A road construction permit shall be obtained from the Public Works Department prior to any construction. The road construction permit shall have the same format as a county access permit. The requirements for access to a public use road are the same as for County roads, except as otherwise noted by this section or by regulations adopted to carry out this standard. No permit or permit fee is required for any maintenance and/or minor construction on a public use road which does not require inspection by the Public Works Department.

A. Opening of an Unopened Public Right-of-Way - Private parties wishing to open a public right-of-way shall apply for a permit and submit plans for review and approval by the Department of Public Works prior to conducting any work. The private parties shall bear all costs for the improvements.

B. Roadway Width and Surfacing - Improvement to an existing or proposed public use road shall have, as a minimum, a gravel surface with adequate drainage. The roadway shall be paved if

specified by County ordinance or the County Engineer or if desired by the applicant. The minimum roadway width and surfacing requirements are shown in Table 3.

**Table 3
Roadway Width and Surfacing**

Number of Dwellings Served	Gravel Surface Width	Minimum Depth of 1 inch-0 Crushed Rock	Asphalt Concrete Thickness
Two or fewer	12 feet	6 inches	2 inches
More than 2	16 feet	8 inches	2 inches

C. Right-of-Way Requirements - Before a private improvement of a public right-of-way will be permitted, the right-of-way must be wide enough to contain the proposed road surface, the cut and fill slopes and the necessary drainage facilities. Dedication of additional right-of-way and/or slope easements may be required prior to the issuance of a permit. The minimum right-of-way widths are shown in Table 4.

**Table 4
Right-of-Way Widths**

Road Type	Min. ROW Width (feet)
New Road longer than 500 feet	60
New Cul-de-Sac less than 500 feet	50 (60 feet preferred)

Note: For a public use road to be accepted by the Board of Commissioners as part of the County Road System, additional right-of-way may also need to be dedicated and developed to the standards shown in Table 6 and Table 7. Additional right-of-way may also be required for new roads located within an adopted urban growth boundary, based on the functional classification of the road and the road standards of the affected city.

VIII. PRIVATE ROADS

The construction and maintenance of a private road are the responsibility of the applicable property owners and/or users. In addition, property owners or users shall be aware that public service vehicles such as fire trucks and ambulances may have need to use a private road in order to perform their public mission.

Unless specified otherwise, the following standards for private roads are required for all new construction of private roads, bridges, and driveways serving residences on lots or parcels within the Timber Conservation (TC) Zoning District and for lots or parcels where the predominant use is forest use in the Farm Forest (FF) Zoning District. For properties in all other zones, these standards are recommended only and are not required.

A. Private Roads Accessing Residences

1) Roads shall be built and maintained to provide a minimum of 12 foot width with an all-weather surface capable of supporting gross vehicle weights of 50,000 pounds, a minimum curve radius of 48 feet, and a vertical clearance of 13 feet 6 inches.

2) Dead-end roads over 150 feet in length shall have cul-de-sac, L-shape, or T-shape turnarounds at the end of the road with dimensions not less than those shown in Standard Drawing 0025. Turnouts, 20 feet wide and 40 feet long (for a maximum combined roadway/turnout width of 20 feet), shall be provided at a maximum spacing of 500 feet.

3) Bridges, culverts, and other structures in the road bed shall be constructed and maintained to support gross vehicle weights of 50,000 pounds.

4) Road grades shall not exceed an average of eight (8) percent, with a maximum grade to be determined by the Public Works Director, but not to exceed 15 percent. Grades in excess of 15 percent may be approved by the Board of Commissioners.

5) It is recommended that all roads be uniquely named or numbered or visibly signed at each road intersection. Letters or numbers should be a minimum of three (3) inches in height and constructed of reflecting material.

IX. USE OF COUNTY RIGHT-OF-WAY BY OTHERS

A. Permit to Work in Public Right-of-Way - A permit to work in or modify a county right-of-way or easement, including the construction of roads and accesses or the installation of utilities, shall be obtained from the County Engineer prior to actual commencement of said work. Such work shall have a warranty for a minimum of one year. The warranty period may be extended to a length of two years, if so determined by the County Engineer. The warranty includes any additional labor, equipment or materials necessary to repair weaknesses or failures identified to the applicant by the Department of Public Works in writing. Standard Drawing 0030 shows backfill requirements for excavation work undertaken in the right-of-way.

B. Location of Utilities - The location of utilities or other facilities in the right-of-way shall be as shown on Standard Drawings 0001 through 0004 and 007A or as authorized by the County Engineer.

C. Utility Cuts in Pavement - Underground utility crossings of paved roads shall be installed by boring, jacking, tunneling, or similar method rather than by excavating or ditching unless authorized by Public Works permit. All utility cuts shall comply with the following standards:

1) Paved roads shall not be cut without approval of the Public Works Director.

2) Where the Public Works Director has approved a utility cut, the pavement shall be saw cut and the crossing shall be perpendicular to the centerline of the road to the extent possible.

D. Construction Requirements

- 1) Depth of conduit: Within the right-of-way of the county road the top of the conduit shall be a minimum of 36 inches lower than the edge of pavement/gravel (if located inside the roadway), the bottom elevation of the roadside ditch (if located inside the ditch section), or existing ground (if located outside the ditch section).
- 2) If excavation is required, such excavation shall comply with Oregon excavation laws as set forth in ORS 757.541 through 757.571. All utilities must be notified before excavation begins.
- 3) Backfill of a paved surface shall be as follows (from bottom of trench to top of trench): granular pipe bedding, 12 inches of granular backfill over top of conduit and 4 inches of asphalt concrete (Class B or Class C), as directed by the County Engineer. Asphalt depth and surface elevation concrete shall match the existing pavement. Trench width shall not exceed the applicable width shown on Standard Drawing 0030.
- 4) Controlled Density Backfill (CDB) is a cement based material mixed, transported, and delivered using normal ready mixed concrete equipment and methods. CDB is a mixture of aggregate (sand or coarse rock), cement, and water that is flowable and requires no compaction. The mixture shall be proportioned such that the 28-day strength is between 50 and 100 pounds per square inch (psi). The material shall be capable of setting up within 24 hours to support paving operations or traffic, regardless of weather conditions, temperature, or moisture content of the soil where placed. Additives such as calcium (1 or 2 percent) and/or hot water to achieve the setup are acceptable. The slump shall normally be 4 inches.
- 5) All waste or extraneous material produced by the project shall be removed from within the right-of-way upon completion of construction.

X. TRANSPORTATION IMPACT ANALYSIS

A. Purpose - A Transportation Impact Analysis (TIA) evaluates the adequacy of the existing transportation system to serve a proposed development and the expected effects of the proposed development on the transportation system. The TIA should provide adequate information for Public Works to evaluate the development proposal and, if necessary, identify traffic mitigation measures.

- 1) Mitigation may require the dedication of land for improving existing roadways or constructing future roadways as development occurs. This includes roadway dedication on lands for which building permits are requested for new structures as well as lands proposed for major development.
- 2) Improvement of existing roadways intersecting or bordering a development to a standard that coincides with anticipated use. The classification of an existing road may increase based upon the results of a traffic analysis. An increase in classification shall necessitate an improvement in the roadway in accordance with Table 7 “Urban Geometric Road Design Standards” and Table 8 “Cul-de-sac Design Standards”.

3) When a development is located within an adopted Urban Growth Boundary (UGB), construction of any new roadways shall conform to the applicable city standards based on the anticipated use and planned functional classification of such roadways. If no such standards have been adopted by the affected city, then the standards of Table 7 and Table 8 shall apply.

B. When a TIA Shall Be Required - A Transportation Impact Analysis (TIA) shall be required for:

1) Any proposed development that can be reasonably expected to generate more than 300 vehicle trips during a single day and/or more than 100 vehicle trips during a single hour.

2) Any development within an adopted UGB, if the development would meet the affected city's criteria for requiring a TIA.

C. When a TIA May Be Required - A Transportation Impact Analysis may be required for:

1) Any proposed development that can be reasonably expected to generate more than 150 vehicle trips during a single day or more than 40 trip ends during a single hour.

2) Any case in which, based on the engineering judgment of the Public Works Department, the proposed development would significantly affect the County's transportation system. Examples of such cases include (but are not limited to) proposals adding additional traffic in areas with acknowledged traffic and safety problems or neighborhood concerns or proposals which would generate a high percentage of truck traffic.

D. Trip Generation Calculation and Distribution - Trip generation data provided in the most recent edition of the Institute of Transportation Engineers (ITE) publication *Trip Generation* should be used unless more appropriate data is available. Average trip generation rates are normally used; however, more conservative rates may be required by Public Works in some cases. Directional trip distribution assumptions should be based on historical data, existing and future travel characteristics and capacity constraints. Public Works may require data collection at similar facilities if staff determines that insufficient trip generation data is currently available. To reduce revisions and review time, approval of the trip generation and distribution assumptions (including any applicable pass-by, internal, or diverted trip percentages) should be obtained from the Public Works Department prior to using these assumptions in the TIA.

E. Transportation Impact Analysis Study Area - The Transportation Impact Analysis shall address at least the following areas:

1) All proposed access points.

2) Any road segment or intersection where the proposed development can be expected to generate more than 150 additional vehicle trips during a single day or more than 40 additional vehicle trips during a single hour (these typical volumes may need to be

adjusted for unusual situations, such as heavy truck traffic, safety issues or capacity limitations). If a two-way stop-controlled intersection currently function acceptably and the proposed development would be expected to generate a total of less than 40 additional vehicle trips per day on the minor leg(s) of the intersection, it need not be included in the study area as part of this requirement.

- 3) Any road segment or intersection where the additional traffic volume created by the proposed development is greater than 10 percent of the current traffic volume (for road segments) or the current entering volume (for intersections).
- 4) For developments expected to generate more than 25 truck trips per day, the TIA study area shall include the route(s) that these trucks would take from the site to and from the arterial system.
- 5) Any other intersections adjacent to the subject property.
- 6) Any other intersections identified by Public Works as having capacity, safety, neighborhood, and/or geometric concerns. Public Works may, at its discretion, choose not to require study of certain minor intersections. Consultation in advance with the Public Works Department to determine the extent of the study is strongly encouraged.

F. Horizon Year - The Horizon Year of a Transportation Impact Analysis is the most distant future year that shall be considered in the TIA. The horizon year will be a specified year after development opens, and this number shall vary depending on the size of the development, its uses, and the anticipated time until full buildout is reached. Table 5 shows the TIA horizon year (expressed in years after the development is planned to open) for developments expected to generate less than three (3) percent truck traffic.

**Table 5
Transportation Impact Analysis - Horizon Year Requirements**

Development Trip Generation Per Day	Horizon Year
Less than 1,000	0 years
1,000 to 1,999	5 years
2,000 to 4,999	10 years
5,000 or more	20 years

For developments expected to generate greater than 3 percent truck traffic, consult Public Works for the TIA horizon year.

G. Transportation Impact Analysis Report Requirements - The preparer is encouraged to coordinate preparation with Public Works and staff from other jurisdictions, if necessary, to assure that all necessary components are included in the TIA and to reduce TIA revision and review time.

In order to be reviewed, the TIA report shall include at least the following minimum components. Incomplete reports will be returned for completion. The Public Works Director

shall specify, in writing, any additional information or analysis to be submitted. The TIA report shall include:

- 1) The signature and stamp by a Professional Civil or Traffic Engineer registered in the state of Oregon.
- 2) A table of contents showing the location of the various elements of the analysis.
- 3) An executive summary, discussing the development, the major findings of the analysis, and the mitigation measures proposed.
- 4) A vicinity map showing the location of the proposed project in relation to the transportation system of the area.
- 5) A complete description of the proposed development, including a site plan, with the best available information as to the nature and size of each proposed use, and the proposed location and traffic control of all proposed access points (including the distance from all proposed access points to the adjacent accesses and/or streets).
- 6) A brief description of the current (and proposed, if applicable) land uses adjacent to the site, including the location, size, zoning, current use, and future use (if known) of any land parcels that are not part of the subject application, but would use the subject parcel for all or part of their access. If the parcel(s) may be developed in the future, include the best available information as to the potential future use of each parcel.
- 7) A description of the TIA study area, including roadway names, locations and function classifications, intersection land configuration and traffic control (including signal timing), existing rights-of-way, transit routes and stops (if applicable), pedestrian and bicycle facilities, such as walkways or bikeways, and planned transportation improvements.
- 8) Existing traffic volumes (measured during design conditions and/or peak season within the previous 12 months, unless Public Works deems newer counts necessary due to recent development or seasonal variation). Consult Public Works to determine what type of count data, (turning movement, ADT, or classification) is necessary.
- 9) Accident data within the study area for the most recent available three-year period (accident data can be obtained from the Oregon Department of Transportation).
- 10) Existing performance of the transportation system, including Level of Service (LOS) calculations and Volume/Capacity (V/C) ratios for all intersections and road segments (as appropriate) within the study area.
- 11) Complete trip generation figures for all aspects of the proposed development, including number of trips by vehicle type and size, and time-of-day and entering/exiting percentages. These figures shall include trip generation figures for any other proposed developments on the subject property, and/or any existing or proposed developments that

would share access to the subject property. For developments expected to generate a significant percentage of truck traffic, include separate figures. The source of all trip generation figures shall be documented. If the source is other than the ITE's *Trip Generation*, the preparer must obtain approval of the use of such data from Public Works prior to including such figures in the TIA.

12) Trip generation figures for any pending and approved developments that would affect the study area. Polk County will facilitate procurement of applicable data in these cases.

13) Identification of the critical analysis period and justification of this identification.

14) Trip distribution for the proposed development. For developments expected to generate a significant percentage of truck traffic, include separate trip distribution figures for trucks.

15) Forecast traffic volumes without the development, in the year that the proposed development is planned to open, and in the horizon year (consult Public Works for information to determine these future traffic volumes). If phased development is proposed, include projections for the year that each phase of the development is planned to be complete.

16) Forecast performance (including LOS and V/C) of the transportation system without the development in the year that each phase is planned to be complete and in the horizon year.

17) Forecast traffic volumes, including the proposed development traffic, in the year that each phase of the development is planned to open and in the horizon year.

18) Forecast performance (including LOS and V/C) of the transportation system, with the proposed development, in the years that each phase of the proposed development is planned to open, and in the horizon year. Include analysis of signal warrants, signal progression, queue lengths, and other traffic flow characteristics as appropriate. For developments expected to generate a significant percentage of truck traffic, demonstrate how the analysis adequately accounts for the presence of these trucks in the traffic flow.

19) Safety analysis of the site access, including sight distance and operational characteristics.

20) Analysis of right and left turn warrants, queue lengths, acceleration lanes, throat lengths, channelization, and other characteristics as appropriate at the site accesses.

21) Comparison of the location and spacing of the proposed accesses with Polk County standards, the standards of the affected city for developments within adopted UGBs, and/or Oregon Department Transportation standards for developments near state highways.

- 22) Analysis of the parking needs of the proposed development, the adequacy of the proposed facilities to meet those needs, and the conformance of the proposed parking facilities to applicable standards.
- 23) Evaluation of the turning characteristics of the vehicles that will be using the proposed development and the adequacy of the geometric characteristics of the existing and proposed roadway.
- 24) Analysis of any potential adverse or controversial effects of the proposed development on the transportation system or quality of life in the area. Examples of such impacts include, (but are not limited to) infiltration of non-residential traffic into residential areas, traffic noise, creation of potential for traffic violations, conflicting turning movements with other driveways, etc.
- 25) Analysis of the effect of the proposed development on pedestrian and bicycle transportation in the area and any new pedestrian and bicycle transportation needs arising from the development.
- 26) Listing of all intersections and locations that are not projected to meet Polk County (or other affected jurisdiction, as appropriate) intersection standards in the TIA study area during the required analysis period (see methodologies for Polk County performance standards).
- 27) Description and analysis of mitigation measures necessary to bring these intersections and locations into compliance with the applicable standards. Include analysis showing that these measures will bring these locations into compliance and include signal, turn lane, or other warrant analyses as appropriate. The TIA shall also specify the timing and phasing of any new traffic signals and the length of any new turn lanes. Any mitigation measures recommended in the TIA shall be shown to be physically feasible. Mitigation alternatives shall include the approximate cost and source of funds available to design and construct the project.
- 28) Copies of raw traffic count data used in the analysis (this may be presented in an appendix).
- 29) Calculation sheets and/or computer software output for all LOS and V/C calculations in the analysis. For signalized intersections, this must include the signal timing used in the analysis (this may be presented in an appendix).
- 30) Warrant worksheets for signals, turn lanes, signal phasing, all-way-stops, and other proposed measures as appropriate (this may be presented in an appendix).

H. Additional Study Requirements - The list of TIA report requirements described above is a fundamental list, but may not be all-inclusive. Additional information and analysis will be necessary to properly analyze many development scenarios, and the TIA shall include a complete analysis of the existing conditions and the proposed development. The applicant

and/or the traffic engineer can and should submit any additional information that may be helpful to Public Works in understanding the proposed development and the traffic it would generate.

Polk County may require additional information beyond the scope of the original TIA, especially in cases where additional transportation system concerns arise as either part of the traffic analysis process, as part of the permit approval process, or from the general public.

I. Methodologies and Analysis Parameters

- 1) All intersection shall operate at Level of Service C or better with a Volume/Capacity of 0.850 or less. Intersections within an adopted UGB shall meet the intersection performance standards of the affected city.
- 2) Acceptable analysis methods include the most recent highway Capacity manual, PASSERII, HRR211, SIGCAP, and UNSIG10 for most cases. For high percentages of truck traffic, unusual types of intersections, or other cases which do not specifically fit the circumstances for which the above analysis tools are intended, or if the engineer believes that another analysis method more accurately models the situation, consult Public Works for determination of the appropriate analysis procedure. Analysis performed using methods not acceptable to Public Works will be returned to the applicant's representative for revision and correction. The Public Works Director shall specify, in writing, any additional information or analysis to be submitted.
- 4) Saturation flow rates greater than 1,800 passenger cars per hour per lane shall not be used unless specifically measured at that location.
- 5) Peak Hour Factors greater than 0.85 shall not be used unless justified by specific measurements in the project vicinity.
- 6) All calculations and analysis results should be reasonable, understandable, consistent, and fully explained. Calculations, graphs, tables, data, and/or analysis results that are contrary to good common sense will not be accepted, and may lead to the TIA being returned to the applicant's representative for correction.
- 7) The conclusions presented in the TIA shall be consistent with and supported by the data, calculations, and analysis in the report. Inconsistent and/or unsupported conclusions will not be accepted, and may lead to the TIA being returned to the applicant's representative for correction. The Public Works Director shall specify, in writing, any additional information or analysis to be submitted.
- 8) Three copies of the TIA report shall be provided to Public Works for review. Additional copies of the report may be required if any portion of the report study area includes roads within another jurisdiction (such as a state highway or city street). The applicant should consult with the affected jurisdiction to determine the number of additional copies necessary for review.

9) Appendix 3 includes a checklist to be used by Public Works to determine if the TIA contains sufficient information to be reviewed. Incomplete and/or unacceptable TIAs will be returned to the applicant's representative for completion and/or correction. Acceptance for review does not certify adequacy and is in no way an approval. Additional information may be required after acceptance of the TIA for review. The Public Works Director shall specify, in writing, any additional information or analysis to be submitted.

10) Cooperation between the applicant, the applicant's traffic engineer, and Public Works is strongly encouraged throughout the process. The applicant or applicant's traffic engineer should not hesitate to contact Public Works if any uncertainties should arise during the TIA process. Polk County assumes no liability for any costs or time delays (either direct or consequential) associated with TIA development and review. The Polk County Public Works Department reserves the right to charge an hourly fee for in-house staff review and/or the appropriate amount due for contracted review service.

J. Traffic Signal Methodologies and Analysis Parameters (applicable within urban growth boundaries)

1) Signal timing used in capacity or progression analysis shall use the same cycle length as is currently in use at the intersection, unless specifically noted otherwise, and shall not exceed 136 seconds. Signal timing shall provide adequate green time for pedestrian crossing in all directions, and shall provide a minimum of 15 seconds of green time for protected left turn phases, and a minimum of 10 seconds of green time protected/permissive left turn phases. Current yellow and all-red time shall not be decreased.

2) Arrival Type 3 (random arrivals) shall be used in signalized intersection analysis unless specific measurements at that intersection indicate otherwise.

3) Signal Progression shall be analyzed in all cases where either a new signal or a change in signal timing is proposed on a roadway with more than two traffic signals (including the new signal, if appropriate) in the space of one mile. A minimum greenband width equal to 40 percent of the cycle length shall be maintained on all arterials, a progression speed within five miles per hour of the posted speed limit.

4) Any proposed signal timing shall provide adequate green time for pedestrians to cross all legs in all directions, at a speed of four feet per second, plus a six-second cushion.

XI. ROADWAY DESIGN STANDARDS

A roadway that is to be constructed within a public right-of-way shall be designed to standards listed herein. Any exception to these standards requires the authorization of the County Engineer, as described in Section XVII. Exceptions may be granted where strict adherence to Standards for a particular road will be in accordance with the County's Transportation System Plan (TSP). The minimum design life for new roadway construction or improvement is twenty (20) years. The minimum design life for bridges shall be fifty (50) years. Bridges shall be designed to

meet recommended AASHTO and ODOT standard specifications, subject to any modifications by the County Engineer.

A. Geometric Design

1) Roads Outside Urban Growth Boundary (UGB): All roads which are outside an adopted UGB shall comply with the standards of Table 6, "Rural Geometric Design Standards" and Table 8 "Cul-de-Sac Standards". Urban design standards may apply to rural roadways adjacent to a UGB if traffic volumes and use so dictate. Standard Drawings 0001 through 0005 and Standard Drawing 0040 show typical sections for County roadways designated as 'rural'. Standard Drawing 0025 shows the dimensions for cul-de-sacs and turnarounds.

2) Roads Inside Urban Growth Boundary (UGB): Roads which lie within a UGB shall be constructed to the applicable city standards based on the anticipated use and planned functional classification of such roadways. If no such standards have been adopted by the affected city, then the standards of Table 7 "Urban Geometric Design Standards" and Table 8 "Cul-de-Sac Standards" shall apply. Standard Drawings 0007 and 0040 show typical sections for County roadways designated as "urban".

B. Design Speed - The minimum design speed for a proposed road or street shall be based upon its functional classification. Table 6 and Table 7 list minimum design speeds for rural and urban areas. The design speed may also be influenced by the 85 percentile vehicle speed. Design speed shall be determined or approved by the Public Works Director.

C. Design Traffic Volume - The design traffic volume shall be based upon functional classification and future traffic projections. Past and current average daily traffic (ADT) volumes shall be used to determine future traffic volumes. Refer to Table 6 and Table 7 for traffic volumes relating to functional classifications.

D. Minimum Grades Along Roadways - To provide adequate drainage along roadways, the minimum slopes shall be as follows:

Tangent Sections and Horizontal Curves

Type A curb and gutter	0.2%
Type C curb and roadside ditch	0.4%
Around Cul-de-sacs and Corners at Intersections (including both curbs and ditches)	0.6%

E. Roadway and Shoulder Width - Roadway and shoulder width shall be determined by functional classification and traffic volume. Roadway width shall provide for all traffic lanes, shoulders, bicycle facilities, mailbox turnouts, and drainage facilities (when required). Bicycle facilities may be required along designated bike routes as described in the Polk County Transportation Systems Plan (TSP). Refer to Table 6 and Table 7 for minimum widths.

- 1) Shoulder width may vary between two (2) feet and six (6) feet depending on functional classification and the determination of the County Engineer. The minimum shoulder width for any roadway classification is two (2) feet.
- 2) The six (6) foot shoulder width may consist of a section of pavement and/or a section of crushed rock.
- 3) The minimum width for paving an existing County gravel road is 18 feet.

Table 6 – see file DESIGN.TAB

Table 7 – see file DESIGN.TAB

Table 8 – see file DESIGN.TAB

F. Side Slopes - Side slopes along and adjacent to the roadway shall be as specified on the standard drawings. In general, they are no steeper than:

Cut Slopes	1½ : 1 (1 : 1 with approval)
Fill Slopes	2 : 1 (others with approval)

If unstable soil conditions exist, flatter side slopes may be required by the County Engineer. On side slopes exceeding five (5) feet in height, the County Engineer may call for stabilization such as seeding/mulching or rip-rap to minimize erosion.

G. Pavement Cross Slope - Pavement cross slope shall be as specified on the standard drawings. Cross slope values range from 2 to 3 percent with the exception of super-elevated sections. Unpaved roads shall have a cross slope of 3 to 5 percent.

H. Cul-de-Sac/Turnaround Standards - Cul-de-sac or turnarounds shall be required on dead end roads and streets to provide an adequate turning area for emergency vehicles. Minimum design standards are shown in Table 8.

- 1) The minimum radius for the transition into a cul-de-sac shall be 25 feet.
- 2) The right-of-way radius within the transition or bulb of the cul-de-sac shall be sufficient to maintain at least the same right-of-way to edge of traffic lane spacing as in the adjacent section of the road.
- 3) The maximum slope from the center of the cul-de-sac to the edge of pavement at the back of the cul-de-sac is 8 percent.

I. Curb and Pavement Radii at 90 Degree Intersections - To allow sufficient pavement for turning, the minimum radii shall conform to Table 9. Intersections with arterials and major collectors shall also include a 10:1 taper (see Standard Drawing 0020).

**Table 9
Turning Radii at Intersections**

Road Classification	Arterial	Major Collector	Minor Collector/Rural Resource Road	Local Road
Arterial	55 feet	40 feet	30 feet	25 feet
Major Collector	40 feet	40 feet	30 feet	25 feet
Minor Collector/Rural Resource Road	30 feet	30 feet	30 feet	25 feet
Local Road	25 feet	25 feet	25 feet	25 feet

1. Edge of radius measured at edge of pavement or curb.
2. If bike lane or on-street parking exists, above radii may be reduced by 5 feet.

J. Sight Distance - Sight distance is one of the most important features involved in roadway design. Adequate stopping sight distance shall be provided along horizontal and vertical curves and at intersections to ensure public safety. Table 10 identifies: (1) design speeds, (2) minimum and desirable stopping sight distances for other than intersections, and (3) the preferred stopping sight distances for intersections. At other than intersections, the desirable stopping sight distance shall be used where possible. At intersections, sight distances less than the preferred stopping sight distance shall require approval by the County Engineer.

Table 10
Stopping Sight Distances (Wet conditions & Level Ground)

Design Speed (MPH)	Assumed Driving Speed (MPH)	Minimum Stopping Sight Distance (Driveways)	Desirable Stopping Sight Distance (Driveways)	Coefficient of Friction (f)	Preferred Stopping Sight Distance for (Intersections)
20	20-20	125	125	0.40	200
25	24-25	150	150	0.38	250
30	28-30	200	200	0.35	300
35	32-35	225	250	0.34	350
40	36-40	275	325	0.32	400
45	40-45	325	400	0.31	450
50	44-50	400	475	0.30	500
55	48-55	450	550	0.30	550
60	52-60	525	650	0.29	575

K. Intersections

- 1) Unpaved county roads that intersect a paved collector or arterial shall be paved for a minimum of 40 feet from the edge of pavement of the collector or arterial, unless a different length is approved by the County Engineer. If conditions dictate, the County Engineer may waive this requirement.
- 2) The interior angle at intersecting roads shall be kept as near to 90 degrees as possible and in no case shall it be less than 30 degrees.
- 3) A tangent section shall be carried a minimum of 25 feet each side of intersecting right-of-way lines.
- 4) The maximum longitudinal slope of all lesser classification or non-through intersecting roads shall be 8 percent for at least 60 feet from the edge of pavement of the intersecting road.
- 5) Grades between 12 and 15 percent shall not be located within 200 feet of an intersection unless approved by the County Engineer.
- 6) Intersections shall be located so as to provide the sight distances specified in Table 10. Where conditions do not allow the Preferred Intersection Sight Distances, the absolute minimum criteria for locating road intersections (including private roads that serve more

than one residence) is the Desirable Stopping Sight Distance. The absolute minimum criteria for locating accesses that serve only one (1) residence is the Minimum Stopping Sight Distance.

a) The sight distance along the roadway shall be measured from a driver's eye, located 3.50 feet above the pavement/gravel, to the top of a vehicle, 4.25 feet above the pavement/gravel. The driver's eye is at a point on the intersecting roadway which is located as follows:

<u>Type of Road</u>	<u>Location of Driver's Eye</u>
Curbed	15 feet preferred and 10 feet minimum behind face of curb
Not Curbed	15 feet preferred and 10 feet minimum behind near face of pavement/gravel

b) In a situation where the specified location of the driver's eye is unsafe or is not adequate to provide the required stopping sight distance, the location shall be determined by the County Engineer.

L. Horizontal Alignment - The minimum horizontal curve radii shall be determined by minimum design speed and maximum superelevation. Table 6 and Table 7 identify the minimum horizontal curve radius and maximum superelevation for each functional classification. When a radius greater than the minimum is selected, the amount that the superelevation may be reduced shall be determined by the County Engineer. Table 11 describes the horizontal alignment based on design speed and various superelevation values. The following formula is used to determine the minimum horizontal curve radii:

$$R = V^2/15*(e+f)$$

Where :

R = minimum horizontal centerline radius (ft)

V = design speed (mph)

e = superelevation, negative on the outside of normal crown and reverse crown (ft/ft)

f = side friction factor

For V = 20 to 30 mph, f = 0.16

For V > 30 mph, f shall be reduced 0.005 for each 5 mph increase in V

Table 11
Design Controls for Horizontal

Design Speed (MPH)	Maximum <i>e</i>	Maximum <i>f</i>	Total (<i>e + f</i>)	Maximum Degree of Curve	Rounded Maximum Degree of Curve	Maximum Radius (ft.)
20	.04	.17	.21	44.97	45.0	127
30	.04	.16	.20	19.04	19.0	302
40	.04	.15	.19	10.17	10.0	573
50	.04	.14	.18	6.17	6.0	955
55	.04	.13	.17	4.83	4.75	1,186
20	.06	.23	.23	49.25	49.25	116
30	.06	.22	.22	20.94	21.0	273
40	.06	.21	.21	11.24	11.25	509
50	.06	.20	.20	6.85	6.75	849
55	.06	.19	.19	5.40	5.5	1,061
20	.08	.25	.25	53.54	53.5	107
30	.08	.24	.24	22.84	22.75	252
40	.08	.23	.23	12.31	12.25	468
50	.08	.22	.22	7.54	7.5	764
55	.08	.21	.21	5.97	6.0	960
20	.10	.27	.27	57.82	58.0	99
30	.10	.26	.26	24.75	24.75	231
40	.10	.25	.25	13.38	13.25	432
50	.10	.24	.24	8.22	8.25	694
55	.10	.23	.23	6.53	6.5	877
20	.12	.29	.29	62.10	62.0	92
30	.12	.28	.28	26.65	26.75	214
40	.12	.27	.27	14.46	14.5	395
50	.12	.26	.26	8.91	9.0	637
55	.12	.25	.25	7.10	7.0	807

1) Horizontal curves shall have long enough radii to provide the minimum stopping sight distances. Sight distances shall be measured across the inside of the curve. Where there are obstructions such as cut slopes, retaining walls, structures, etc. radii longer than the minimums specified in Tables 6 and 7 may be required.

2) Centerline alignment of roadway improvements shall be parallel to the centerline of the right-of-way.

3) Centerline of a proposed road extension shall be aligned with the existing road centerline.

- 4) Off right-of-way runoff shall be controlled to prevent concentrated cross flow in superelevated sections.

- 5) For urban areas, when superelevation is used, road curves shall be designed for a maximum superelevation rate of 0.04. If terrain dictates sharp curvature, a maximum superelevation rate of 0.06 is justified if the curve is long enough to provide an adequate superelevation transition. For rural roads, superelevation values of 0.06-0.08 are reasonable to allow for sharper curves and reduce the cost and/or required right-of-way for a new road. Based on topography and alignment restrictions, the Public Works Director may approve superelevation values of up to 12 percent.

- 6) On local streets, requests for design speeds less than 25 mph shall be based on topography, right-of-way, or geographic conditions that impose an economic hardship on the applicant. There shall be posting requirements associated with designs below 25 mph.

- 7) Centerline radius shall not be reduced to meet the requirements of 6 above, unless the reduction of centerline radius does not compromise safety.

M. Vertical Alignment - To provide adequate stopping sight distance, the minimum lengths of vertical curves shall be as computed from the following formula but in no case shall the lengths be less than 50 feet:

$$L = KA$$

Where:

L = Length of vertical curve (ft)

K = Constant for design, see Table 12

A = Algebraic difference in grade (%)

When the algebraic difference in grade is less than one (1) percent, a vertical curve shall not be required.

Table 12
Design Controls for Vertical

Design Speed (MPH)	K Crest	K Sag
20	10-10	20-20
25	20-20	30-30
30	30-30	40-40
35	40-50	50-50
40	60-80	60-70
45	80-120	70-90
50	110-160	90-110
55	150-220	100-130
60	190-310	120-160

1) Effect of Grade - The minimum stopping sight distances (SSD) specified in Table 10 are for level ground. Where the grade is not level, the minimum stopping sight distance shall be determined by the following formula:

$$SSD = 3.68 * V + V^2 / (30 * (f + g))$$

Where:

SSD = minimum stopping sight distance (ft)

V = design or driving speed

g = grade (+ for upgrade and - for downgrade)

f = coefficient of friction for wet pavement from Table 9

Example: For 6% downgrade at 55 mph SSD = 625 feet

For 6% upgrade at 55 mph SSD = 485 feet

For level ground at 55 mph SSD = 550 feet

2) Minimum tangent road gradients shall be one-half (0.5) percent along the crown and curb.

3) Maximum road gradients should be twelve (12) percent for minor collectors and local roads, and ten (10) percent for all other roads. Grades in excess of twelve (12) percent shall be approved by the County Engineer on an exception (variance) basis.

4) Local roads intersecting with a minor collector or greater functional classification road or roads intended to be posted with a stop sign shall provide a Safe Stopping Area that shall have a grade not greater than eight (8) percent. The Safe Stopping Area is that portion of the road that is within 60 feet of the edge of roadway of the intersecting road.

5) Grade changes of more than one (1) percent shall be accomplished with vertical curves.

6) Road grades, intersections, and superelevation transitions shall be designed to not allow concentrations of storm water to flow over the road.

7) Offset crowns may be approved by the County Engineer on a case-by-case basis.

8) Slope easements shall be dedicated or obtained for the purposes of grading outside of the rights of way.

N. Right-of-Way Widths - Right-of-way width for each functional classification shall provide sufficient widths to incorporate all standard roadway and roadside improvements including utilities. Required widths for roadway right-of-ways are listed by functional classification in Table 6 and Table 7. The County Engineer may approve a lesser right-of-way width may be allowed where physical conditions dictate.

O. Curbs and Sidewalks - Curbs and/or sidewalks may be required within areas zoned with parcel sizes less than or equal to one (1) acre. See Table 6 for minimum requirements. Curbs and sidewalks shall be constructed according to Standard Drawings 0016 through 0018. Sidewalks shall be five (5) feet wide unless otherwise specified by the County Engineer. If areas requiring curb

and/or sidewalk are also within a UGB, curbs and sidewalks shall comply with the standards of the affected city.

P. Bicycle Facility - Unless otherwise authorized by the County Engineer, the standard bicycle facility within the County shall be a bikeway. A bikeway is created when a road has design features which accommodate bicyclists. Based on motor vehicle volumes and speed these features may include a shared roadway, shoulder bikeway, or bike lane.

1) For any road which is not designed in the County Transportation System Plan as a bike route, the County Engineer shall determine the type of bikeway facility to be constructed. In making such a determination, the County Engineer shall consider the functional classification of the road, current and future traffic volumes and speeds on the proposed facility, as well as physical site constraints.

2) Any road that is designated in the County Transportation System Plan as a bike route shall have paved shoulders.

Q. Traffic Control - Traffic control devices shall be required according to current edition of "The Manual on Uniform Traffic Control Devices" published by the U.S. Department of Transportation and any applicable ODOT supplements.

XII. PAVEMENT DESIGN STANDARDS

It is the responsibility of the construction agent to determine the required pavement and aggregate base thickness based on soils analysis and current as well as future traffic volumes. Unless otherwise authorized by the County Engineer, pavement and aggregate thickness shall be determined in accordance with Reference N (see page 53). General guidelines for pavement and aggregate base thickness are contained in Table 13. These guidelines are not a substitute for pavement thickness analysis using the AASHTO flexible pavement design procedure. Proposed pavement thickness determined using pavement analysis software shall be accompanied by sufficient explanatory assumptions and data.

**Table 13
Pavement and Aggregate Structural Standards**

Street/Road Classification	Asphalt Concrete	Aggregate Leveling Course (3/4 inch-0) or (1 feet-0)	Aggregate Base Course (1 1/2 inch-0)	Curb Exposure	Engineering Data Crushed Base Equivalent
RURAL					
Local	2-1/2 in.	1-1/2 in.	7-1/2 in.	None	14 in.
Collector	4 in.	1-1/2 in.	11 in.	None	20-1/2 in.
Arterial	4 in.	1-1/2 in.	14 in.	None	23-1/2 in.
URBAN					
Local	2-1/2 in.	1-1/2 in.	7-1/2 in.	6 in.	14 in.
Collector	4 in.	1-1/2 in.	12 in.	7 in.	21-1/2 in.
Arterial	4 in.	1-1/2 in.	15 in.	7 in.	23 -1/2 in.

1. These guidelines shall not be used without first considering traffic volume and soil conditions at subgrade.

A. Conditions for Paving a New Road - New roads shall be paved in accordance with Table 14.

**Table 14
Paving Requirements for New Roads**

Road Class	Paving Required
Major Collector	Yes
Minor Collector	Yes
Resource Road	No (unless required based on traffic volume)
Local	Yes - if inside a UGB or within one (1) mile of a UGB (if applicable)
Local	No - if more than one (1) mile outside a UGB (unless required within a subdivision)

B. Conditions for Paving an Existing Gravel Road - An existing gravel road may be paved when the Average Daily Traffic (ADT) exceeds 350 vehicles per day for the section to be paved and the Board of Commissioners determines that the proposed paving is in the County's best interests and is economically feasible. The County shall bear the full cost for the paving. Other circumstances, such as a cost share project, may cause a section of road to be paved prior to attaining an ADT of 350. Paving requirements shall be in accordance with Tables 6 and 7.

XIII. DRAINAGE STANDARDS

A. General

1) These standards shall apply to all drainage facilities in existing and proposed county road rights-of-way, public rights-of-way, or public drainage easements. Storm drainage systems include, but are not limited to, inlets, pipes, ditches, creeks, rivers, and runoff detention facilities.

2) All storm water runoff shall be conveyed to a public storm sewer, or an existing drainage facility, having adequate capacity to carry the flow without overflowing or otherwise causing damage to public and private property, as shown in Table 18. In the case of private development, the construction agent shall pay all costs associated with designing and constructing the facilities necessary to meet this requirement and shall provide Polk County with any necessary access easements for future maintenance purposes.

B. Pipes

1) All pipes and culverts shall hereafter referred to as pipes have a minimum of twelve (12) inches in diameter unless otherwise approved by the County Engineer. For pipes and culverts not of circular cross-section, the minimum rise dimension is twelve (12) inches unless otherwise approved by the County Engineer. Minimum cover is twelve (12) inches.

2) Acceptable pipe material includes concrete pipe, corrugated steel pipe, or high density polyethylene pipe with a corrugated exterior and a smooth interior (Advanced Design Systems, Inc., N-12 or equivalent). The required type and class of pipe shall be specified based on the cover, anticipated loading, bedding and trench conditions. When the pipe has less than 12 inches of cover, ductile iron, Class 52 shall be installed if specified by the County Engineer.

3) All pipes shall have a sufficient slope to maintain a minimum flow velocity 2.0 feet per second (fps) at peak design flow.

4) All pipe outlets with exit velocities in excess of four (4) fps shall have erosion control protection such as rip-rap. Where grades require, all end pipes shall be supported by tie downs, end walls or aprons, etc. to prevent the separation and dislodging of pipe sections.

5) Pipe slopes greater than 20 percent shall have concrete encasement or anchor walls at 21 foot spacing, and energy dissipaters.

6) No curved storm drain pipes shall be allowed by joint displacement or deflection if it results in a joint that allows the adjacent soil material to enter the pipe. Joints with rubber gaskets shall be used for all curved storm drains. Minimum radii shall be as shown in Table 15.

**Table 15
Tongue and Groove Pipe on Curved Alignment**

Pipe Diameter (in)	Minimum Radius of Curvature in Feet ¹										
	Length of Pipe Section in Feet ²										
	3.5	4	6.5	7.5	8	8	8	8	8	8	8
10	128.0										
12	149.0		277.0								
15		208.0		390.0							
18		245.0		460.0	121.0						
21		283.0		530.0	160.0	176.0	192.0				
24		320.0		600.0	195.0	215.0	234.0	254.0	273.0	292.0	311.0
27		357.0			230.0	253.0	276.0	299.0	322.0	346.0	369.0
30		395.0			265.0	292.0	318.0	345.0	371.0	398.0	425.0
36		469.0			300.0	330.0	360.0	390.0	420.0	450.0	480.0
42		560.0			335.0		402.0		469.0		536.0
48		635.0			370.0		444.0		518.0		592.0

¹ Table is based on maximum joint deflection of 3/8 inch.

² Check with manufacturer on pipe lengths available.

Note: Table is based on $R=32xDxL$ where R=min. radius (ft.), D = pipe O.D. and L= pipe section (ft.)

7) Tongue and groove joints are preferred and shall be used when commercially available in the size required. Joints used shall meet the manufacturers recommendations.

8) Pipe bedding and trench backfill shall conform to Standard Drawing 0030.

9) Storm sewers crossing private property shall have minimum easement widths of 10 feet. Deep storm sewers, large pipe or unstable soil situations may require wider easements.

10) Storm sewer lines should not meander across the road right-of-way, creating conflicts with existing and future utilities and preempting orderly future installation. With few exceptions, underground utilities on urban streets shall parallel the roadway centerline and be placed per Standard Drawing 0007A.

11) Allowance for energy loss due to turns, structures, pipe size change, etc., shall be considered in the design of the storm drainage facilities.

C. Inlets (Curb and Gutter) and Catch Basins

1) Catch basins and inlets shall be required at:

a) A gutter length that will limit the depth of flow against a curb to not more than four (4) inches, designed for those rain events shown in Table 17.

b) A maximum gutter flow length of 500 feet.

- 2) Catch basin and inlets shall be of sufficient size to accept the inflows without backing up water on the roadway which would create a driving hazard (see Standard Drawings 0031A through 0031C).
- 3) Catch basins with inlets, either standard or oversize, shall be used on all streets with curbs.
- 4) Catch basins with inlets shall be located just prior to curb returns on streets with a centerline grade of three (3) percent or more and a street gutter drainage run of 100 feet or more.
- 5) Standard catch basins shall have a maximum height from top of grate to flow line of pipe of three and one-half (3 1/2) feet and shall be used with a maximum pipe diameter of 27 inches in the side walls and 12 inches in the end walls. Minimum depth shall be pipe diameter plus 12 inches.
- 6) Oversize catch basins and gutter inlets shall have a maximum height from top of grate to flow line of pipe of six (6) feet and shall be used with a maximum pipe diameter of 27 inches in both the side and end walls. Minimum depth shall be pipe diameter plus 12 inches.
- 7) Pavement tapers are required for all catch basins and gutter inlets. Within two (2) feet of the catch basin or inlet, the pavement shall drop 1 1/2 inches to the catch basin or inlet.

D. Storm Drain Manholes, Junction Boxes, and Cleanouts

- 1) Manholes shall be required at:
 - a) Abrupt changes in horizontal alignment or vertical alignment and grade of storm drain pipes. Minor horizontal curvature in pipe less than 15 degrees may be allowed without manholes or cleanouts, depending on pipe size, street alignment, degree of curvature and reason. Maximum joint deflection shall be per manufacturer's recommendation or per Table 14.
 - b) All connections, except as provided by subsection 4 below (see Standard Drawing 0037).
 - c) All changes in pipe size.
 - d) At a spacing such that no pipe has a continuous run of 500 feet without access from a catch basin, curb inlet, ditch inlet, open end pipe or manhole (400 feet is the desired maximum).
 - e) Uppermost extent of storm pipe not daylighted to receive ditch or other open conveyance flows. Cleanouts are not allowed in this situation.

- 2) Standard catch basins, junction boxes, or cleanouts may be used in place of manholes for pipe no larger than 18 inches and with a depth less than 4.0 feet. Cleanouts shall not be used in ditch areas that are mowed or gravel shoulders that are graded.
- 3) In place of manholes on new main line and lateral construction, catch basin laterals of 30 feet or less in length and 10 inches in diameter may connect to the main line with a shop fabricated 90 degree "T", provided the connection is located not more than 100 feet from a manhole or cleanout on the main line and the main line is 12 inches or larger in diameter.
- 4) In place of manholes or cleanouts, laterals draining private property may be connected directly to the main line, provided the lateral diameter is 8 inches or less and is not more than one half the diameter of the main line. The hole in the main line shall be made with a drill designed for cutting concrete. The connection shall be properly grouted to provide a strong, leak-proof point. The lateral shall not project inside the main line.
- 5) Manholes and catch basins deeper than four (4) feet shall have steps installed.
- 6) Manholes shall have two-hole lids. Heavy duty frames and covers shall be used on all manholes (see Standard Drawing 0037).
- 7) All manholes shall have the outlet pipe invert at least two-tenths (0.2) of a foot in elevation lower than all inflow pipe inverts, in addition to the normal slope of the manhole.
- 8) Manholes shall not have open grate lids with the intent to receive surface flows. Catch basins or curb inlets shall be used as appropriate.
- 9) The County allows directional grates on catch basins to increase hydraulic efficiency.

E. Open Channels

- 1) All existing streams and ditches and other open channels requiring a pipe diameter greater than 36 inches shall remain open channel except at road crossings.
- 2) Where possible, ditches shall be located along or adjacent to lot lines. Within a UGB, creation of new open channels or the relocation/alteration of existing ditches shall not be allowed unless it is approved by the County Engineer.
- 3) For reasons of maintenance and safety, the ditch foreslope generally shall be 3:1 or flatter. Backslopes shall be no steeper than 1 1/2:1. A ditch foreslope greater than 1 1/2:1 may be approved by the County Engineer, based on soil/drainage characteristics and location.
- 4) The minimum allowable design flow velocity shall be 2 fps when flowing full.

- 5) All proposed or modified channels shall have adequate erosion control provisions to prevent damage to the shoulder of the adjacent road or the water course channel. Slope protection such as rip-rap, matting, and/or seeding and mulching may be required.
- 6) Maximum depth of a ditch adjacent to a roadway shall be two (2) feet as measured from the shoulder of the road where feasible and appropriate for drainage purposes. Maximum depth of a ditch outside of a county or public right-of-way shall be four (4) feet, unless approved by the County Engineer.
- 7) Channels crossing private property shall have a minimum easement width equal to the channel width at the top plus 10 feet along on the side of the channel.
- 8) No protruding pipes, culverts or other structures that reduce or hinder the flow of a ditch channel or creek shall be authorized.

F. Drywells and French Drains - Drywells and french drains shall not be allowed as the exclusive method for draining public right-of-ways but may be used for developments on private property for paved driveways, parking and loading areas, subject to the following conditions:

- 1) There are no public storm drain facilities available within a reasonable distance of the development.
- 2) A soils test shall be provided to show that there is adequate permeability.
- 3) The system shall be engineered to insure that adequate capacity is available.
- 4) The site shall be graded so that it does not drain on to a public right-of-way in the event that the drywell or french drain fails.
- 5) The design shall be approved by the County Engineer (see Standard Drawing 0039).

G. Design Considerations

- 1) Overall System Design Considerations: Improvement projects shall address more than just the on-site drainage concerns. The off-site concerns, both upstream and downstream of a project, are critical to the development of proper improvements.
- 2) Impact on Upstream Off-Site Property: Modifications to on-site storm drainage facilities shall not restrict flows creating backwater on to off-site property to levels greater than the existing situation.
- 3) Impacts on Downstream Off-Site Property:
 - a) Modifications to on-site storm drainage facilities shall not move the location of the runoff outflow without executing properly recorded agreements with all affected downstream property owners.

- b) Proposed concentration of outflows shall not be allowed without executing properly recorded agreements with all affected downstream property owners between the release point and an existing defined receiving conveyance such as a pipe, culvert, ditch, creek, river, etc. and approved by the County Engineer.
 - c) Agreements described above shall include, but are not limited to, executions of the proper easements in favor of the public and construction of conveyance facilities satisfactory to all affected property owners and the County.
 - d) Siltation of receiving streams due to construction of roads, drainage facilities, and utilities shall be prevented through the use of temporary on-site siltation detention systems. Such systems shall be subject to County approval. Erosion control plans and details may be required by the County as part of the regular plan submittal.
- 4) Upstream Impact on On-Site Property: Storm drainage facilities shall be designed and constructed to accommodate all flows generated from upstream off-site property.
- 5) Downstream Impact on On-Site Property: Storm drainage facilities shall take into account the impact of downstream restrictions on the project area. A situation that causes existing on-site backwater shall either be removed by the construction agent or their impact incorporated into the on-site design.
- 6) Flow Capacities:
- a) Open channels and Pipes/Culverts
- For inlet control (upstream control) and outlet control (downstream control), flow capacity shall be determined using a method described in the latest edition of the ODOT Hydraulics Manual.
- b) Catch basins, curb inlets, and gutter inlets shall conform to the standards of Table 16.

Table 16
Catch Basin and Curb Inlet Capacities

Structure Style	Maximum Allowable Intake Flow Rate (cfs) Centerline Street Gradient (%)		
	0 (SAG)	Less than 6	6 or more
Standard Catch Basin w/pavement taper ¹	N/A	3.0	N/A
Oversize Catch Basin w/pavement taper ¹	8.0	4.5	N/A
Standard Curb Inlet w/pavement taper	N/A	3.5	2.5
Oversize Curb Inlet w/pavement taper	8.0	5.0	3.5
Gutter Inlet 2 1/2A w/pavement taper 2 1/2 in.	4.2	N/A	N/A
Gutter Inlet 4A w/pavement taper 2 1/2 in.	6.7	N/A	N/A

N/A - Not allowed in this situation
¹ Not allowed on streets with curbs.

c) Area drains: See Table 17.

Table 17
Area Drain Capacities (Type II)

Hydraulic Head (ft) ¹	Grate Angle 30 degrees									
	0.5	1.0	1.5	2.0	2.5	3.0	4.0	5.0	7.0	10.0
Flow Rates (C)	2.0	5.6	10.3	11.9	13.3	14.6	16.8	18.8	22.3	26.6

¹ Measured from bottom of grate to headwater.

H. Design

- 1) Calculations - Design calculations shall be submitted for all drainage facilities. Peak design discharges shall be computed using the rational formula, $Q=CIA$, only for basins under 1,000 acres. For larger basins, gauged flows or Natural Resource Conservation Service or other approved methods shall be used.

- 2) Design Storm: All conveyance components (catch basins, inlets, manholes, pipes, culverts, ditches, ditch inlets, etc.) shall be designed to provide a level of protection from damages due to flooding. This means that all surface runoff waters shall pass through a conveyance system without flooding roads, streets, public and private property and other items of value not normally publicly acceptable to be flooded in accordance with the following storm event frequency:

Table 18
Design Storm Frequency

Area	Frequency
Residential	5 year storm
Commercial District	10 year storm
Trunk lines (>24 inch pipe)	25 year storm
Minor Creeks and Drainage Ways (not designated with a 100-year floodplain on the Flood Insurance Rate Map)	50 year storm
Major Creeks (designated with a 100-year flood plain on the Flood Insurance Rate Map)	100 year storm

Design flows shall be based on the maximum runoff created by existing land uses, the maximum potential zoning, or a combination thereof.

b) Drainage Basin Area (A): The drainage basin area used in the design of storm drain facilities shall include all the areas that are or will be tributary (both on and off the project site) to the location under consideration. Area is measured in acres.

c) Runoff Coefficients (C): The runoff coefficients used in the design of storm drain facilities shall vary depending on existing land uses and the maximum potential zoning of all land tributary to the location under consideration. Table 19 shows minimum acceptable values for the coefficients. The composite runoff coefficients shall be the acceptable form and standard for this parameter.

Table 19
Composite Runoff Coefficients

Land Use	Flat Terrain s<2%	Rolling Terrain 2%<s<10%	Steep Terrain s>2%
Commercial or Industrial	0.70	0.80	0.90
Multiple Family	0.60	0.65	0.70
Duplexes, Single Family	0.50	0.55	0.60
Single Family	0.40	0.45	0.50
Mobile Home Parks	0.60	0.65	0.70
Parks, Agricultural or Undeveloped	0.20	0.25	0.30

In some cases the use of individual characteristic runoff coefficients is more appropriate than composite coefficients. Project specific composite coefficients can be calculated from an area-weighted-average basis using characteristic coefficients. Table 20 shows minimum acceptable values for the coefficients. The characteristic runoff coefficients shall only be used when approved by the County Engineer.

Table 20

Characteristic Runoff Coefficients

Land Characteristic	Flat Terrain	Rolling Terrain	Steep Terrain
	s<2%	2%<s<10%	s>2%
Roofs and paved areas	0.85	0.90	0.95
Gravel parking lots	0.50	0.55	0.60
Lawns, pasture, woods	0.20	0.25	0.30
Bare soil	0.30	0.35	0.40

d) Rainfall Intensity-Duration (I): The rainfall intensity used in the design of storm drainage facilities shall vary depending on the time of concentration for the drainage basin that is tributary to the location under consideration. The rainfall intensity-duration curves for Polk County are available from the Public Works Department. Intensity is measured in inches per hour.

e) Time of Concentration: The time of concentration shall be calculated as the time required for all portions of the drainage basin to contribute to the location under consideration. This time is the sum of travel times for overland flow from the most remote part of the drainage basin to the headwaters of the conveyance system.

Table 19 shows the acceptable values for overland flow travel time for sheet flow conditions. For developed residential and commercial/industrial property, the maximum time of concentration from the most remote point in the development to the closest inlet shall be 10 minutes or the results of Table 21, whichever is less.

**Table 21
Overland Flow Travel Time of Concentration¹**

Length of Overland Flow (ft)	Surface Type ²														
	Vegetated					Bare Soil					Rooftop/Pavement				
	Average Gradient of Terrain														
	1% or less	2%	4%	7%	10% or more	1% or less	2%	4%	7%	10% or more	1% or less	2%	4%	7%	10% or more
50	11	10	8.5	7.5	7	6.5	5.5	4	3.5	3	4	3	2	2	2
100	15	13	11.5	10	9	8.5	7.5	6.5	5.5	5	5	4	3	2	2
200	20	17	15	13	12.5	11	9.5	8.5	7.5	7	6	5	4	3	2
300	23	20	18	16	14	13	11.5	10	9	8	7	6	5	4	3
400	25	22	20	18	16	15	12.5	11	10	9	8	6.5	6	5	4
500	28	24	22	19	18	16	14	12.5	11	10	9	7	6.5	6	5
700	33	28	25	22	20	18	16	14	12	11	10	8	7.5	6.5	6

¹ This table applies to sheet flow conditions only. Travel time is in minutes.

² Surface Type: A = Grassy; B = Bare Soil; C = Rooftop/Paved

For land in a pre-development (rural) condition, the minimum time of concentration from the most remote point in the basin to the first defined channel (e.g. gutter, ditch or pipe) shall be 10 minutes. Longer times may be calculated using the Natural Resource Conservation Service (NRCS) method or other approved methods.

Open channel flow velocity will be based on the flow concentration characteristics of the particular rain event.

The benefits of upstream detention systems shall not be accounted for in determining the time of concentration for any storm drainage system.

2) Detention Facilities

a) Requirement: Peak storm water runoff shall be controlled by detention facilities for all subdivisions, all commercial and industrial developments and all parking lots with a total developed acreage of 0.5 acres or more and all other developments where the County Engineer determines control is needed to prevent flooding or damage downstream. This requirement may be waived if the applicant can show that it is not effective for the basin as a whole.

b) Allowable Runoff Rate (Outflow): Peak runoff rate shall be limited to that which would occur in a 5-year frequency storm with pre-development conditions ($C=0.2$).

c) Required Storage Capacity: Detention facilities shall have storage capacities to detain the difference between a 5-year frequency storm with pre-development conditions and a 10-year frequency storm with development conditions.

d) Design:

(1) The design shall be done in accordance with the Oregon Department of Transportation Publication 78-4, *"Procedure Manual, Application of Detention Storage for Limiting Runoff"*, or other methods approved by the County Engineer.

(2) The orifice size and the hydraulic head shall be adjusted to produce the allowable outflow.

(3) To prevent excessive plugging, the minimum orifice diameter shall be 1-½ inches.

(4) Detention facilities shall be designed to protect public and private property. The location of detention facilities shall be approved by the County Engineer.

(a) Freeboard: At maximum storage, the water surface elevation shall be a minimum of 0.5 feet below the top of the structure (curb, bank, berm, etc.) designed to contain the water.

(b) Overflow System: The detention facility shall have an overflow system with the capacity to pass a 50-year frequency storm. The overflow shall discharge into a public storm drain facility or the natural basin where the development is located.

(5) Simplified design for sites between 0.5 acres and 5 acres. For developments in this size range, the detention facility may be designed in accordance with Standard Drawing 0038. This method is based on the following conditions:

(a) The sites are small enough so that there is an insignificant difference between the times of concentration for the different site sizes. For calculating the allowable runoff rate, a uniform time of concentration of 10 minutes is applicable and, as a result, the allowable runoff rate is 0.2 cfs per acre.

(b) The sites, when developed, will have surfaces that are almost entirely impermeable (buildings, pavement, etc.). For a site not conforming to this condition, the required storage capacity can be reduced by doing a detailed analysis instead of following the standard drawing.

XIV. STRUCTURAL STANDARDS

The structural and geometric design of bridges, culverts, walls, and other structures shall be in accordance with current ODOT standards. These include, but are not limited to, ODOT Standard Drawings and the current edition of "*Standard Specifications for Highway Bridges*" (AASHTO). The minimum design loading for new vehicular bridges shall be HS-25. Minimum roadway widths for new and reconstructed bridges or culvert structures shall be in accordance with AASHTO standards or those Polk County standards as to minimum width.

XV. CONSTRUCTION STANDARDS

All construction work and materials shall be in accordance with the current edition of "*Standard Specifications for Highway Construction*" published by ODOT and/or the current edition of "*Standard Specifications for Public Works Projects*" published by the Oregon Association of Public Works.

XVI. ROADWAY DELINEATION

A. Engineering Analysis - Before any new delineation is installed, an engineering analysis shall be performed. The engineering analysis shall include a review of accident rates, pavement and shoulder widths and materials, roadside vegetation, horizontal and vertical roadway alignment, existing and recommended vehicle speeds, traffic volumes, adjacent land use, weather, and any other pertinent items. The engineering analysis shall always include an on-site evaluation.

B. Consistency of Installation of Delineation

1) Delineation shall be installed in a consistent manner both along a given section of road and, to the extent economically practical, throughout the entire road system. For

example, if a curve of a particular radius is marked with delineators on a road, similar curves should be similarly marked on that road. It should, however, be recognized that curves that appear similar on a map or construction drawing may have entirely different appearances in their individual surroundings.

2) Both for the purpose of consistency and to avoid diminishing effectiveness due to overuse, delineation shall be accomplished in accordance with the following priorities:

- a) Turn and curve warning signs, with or without advisory speed plates;
- b) Painted yellow centerline;
- c) Painted white "fog" lines;
- d) Chevron alignment signs;
- e) Large arrow signs; and
- f) Raised reflective pavement markers.

Items a, b, and f may be used on both tangents and horizontal curves whereas items c, d, and e may be used only on horizontal curves.

3) The selection of the delineation to be installed at a particular location shall be based on the priorities listed above, the results of an engineering analysis, and the following conditions established in the Manual on Uniform Traffic Control Devices.

a) Painted yellow centerlines and painted white "fog" lines constitute the standard delineation for all paved roads at least 18 feet wide. Other types of delineation shall supplement rather than replace these painted lines. Where intersections are located in a curve, the centerline stripe shall be continued through to the corner to protect public safety, unless otherwise specified by the County Engineer.

b) Turn and curve warning signs and advisory speed plates.

(1) The turn sign is intended for use where an engineering analysis shows that the recommended speed on a turn is 10 mph less than the recommended speed limit.

(2) The curve sign is intended for use where an engineering analysis shows that the recommended speed on a turn is greater than 30 mph (~~18 kph~~) and is equal to or less than the legal speed limit.

(3) The advisory speed plate is intended to supplement the turn and curve signs to give additional warning. It shall not be used alone. It shall show the maximum recommended speed.

c) Chevron Alignment Sign: The purpose of the chevron alignment sign is to give notice of a sharp change in roadway alignment and to provide additional guidance for vehicle operators. Chevron alignment signs are normally installed in groups of three or more with spacing such that drivers always have two in view as they proceed around the curve. The number of chevron alignment signs may be reduced to two for

roads with an ADT less than 500. Chevron alignment signs are installed on the outside of a curve at right angles to approaching traffic. The first two should be visible for at least 500 feet from the approach to the curve.

d) Large Arrow Sign: The purpose of the large arrow sign is also to give notice of a sharp change in roadway alignment. It should be used to mark curves that have a high accident experience (normally more than 3 accidents within a 12 month period). The large arrow sign shall be located on the outside of the curve in line with and at a right angle to approaching traffic. It should be visible for at least 500 feet from the approach to the curve.

e) Raised reflective pavement markers

(1) Raised reflective pavement markers shall be installed on roads as specified by the County Engineer after Board of Commissioners' approval. Pavement markers are typically used on sharp curves or locations with an accident history.

(2) Pavement markers shall be spaced 80 feet apart on tangents and 40 feet apart on curves.

(3) Where pavement markers are to be installed only on a curve, markers shall also be installed on the approach tangents for a distance of 500 feet in each direction from the curve. On these tangents, the marker spacing shall be 250 feet.

(4) Pavement markers shall not be installed in areas where snow removal operations are expected. A rule of thumb - markers shall not be installed at elevations greater than 500 feet above mean sea level.

f. Delineators (Reflectors Mounted on Posts)

(1) Delineators may be installed when directed by the County Engineer and in accordance with the standards of Table 22.

**Table 22
Delineator Warrants**

Traffic Volume (ADT)	Road Class	Install Delineators
0-500	Local	Only in special cases where justified by an engineering study
500-1000	Minor Collector/Resource Road	On curves sharper than 12 degrees (radius less than 660 feet)
>1000	Major collector	On curves sharper than 6 degrees

(2) Delineators may be installed on curves when raised reflective pavement markers alone have been found to be inadequate. Such situations may occur where a crest vertical curve blocks the driver's view of the pavement markers within the safe stopping sight distance or where the need for additional advance warning is demonstrated by the occurrence of accidents (normally more than 3 accidents within a 12 month period).

(3) Delineators shall not be installed within any urban growth boundary, unless specified by the County Engineer.

(4) Delineators on horizontal curves shall be spaced in accordance with the standards of Table 23.

**Table 23
Delineator spacing on Horizontal Curves**

Radius of Curve (ft)	Spacing (S) on Curve (ft)	Spacing in Advance of and Beyond Curve (ft)		
		First Space	Second Space	Third Space
50	20	2S	3S	6S
150	30	2S	3S	6S
200	35	2S	3S	6S
250	40	2S	3S	6S
300	50	2S	3S	6S
400	55	2S	3S	6S
500	65	2S	3S	6S
600	70	2S	3S	6S
700	75	2S	3S	6S
800	80	2S	3S	6S
900	85	2S	3S	6S
1000	90	2S	3S	6S

(a) For curves falling between the values listed, use the spacing given for the next sharper curve.

(b) To clear driveways, crossroads or intersections, either vary placement of the delineator up to 1/8th of the spacing shown, or if that will not work, then eliminate the delineator.

(5) Delineators shall not be installed if their placement shall unduly hamper road maintenance operations, particularly ditching.

(6) Delineators shall not be located in areas that are actively farmed unless they can be placed far enough off the pavement to avoid being hit by farm machinery.

(7) Delineators, supplemented by reflectors, may be placed on both sides of horizontal curves.

(8) The use of chevron signs or large arrow signs may be considered on all curves sharper than 30 degrees (radius less than 350 feet).

XVII. EXCEPTION PROCESS FOR ROADWAY DESIGN STANDARDS

A. Submittal of Request for Exception - Requests for exceptions to roadway design standards must be submitted to the County Engineer, in writing.

B. Submittal Description - The written request shall state the desired modification(s), the reason(s) for the request(s), a comparison between the proposed modification and the county standard in terms of performance (the degree to which the county standard is reduced), safety, cost, and environmental impact, and a description of any measures the applicant would accomplish to mitigate a reduction in a county standard. If required by the County Engineer, the submittal may also include a Transportation Impact Analysis (see Section X).

C. Review of Request for Exception

1) The County Engineer shall review all requests for exception to county road standards and make one of the following decisions: approve as is, approve with changes, or deny with an explanation.

2) Approval of a request shall not constitute a precedent.

D. Appeal of County Engineer Decision - The applicant may appeal the County Engineer's decision to the County Board of Commissioners.

E. Criteria for Granting an Exception - The County Engineer may grant an exception to a county road standard under any one of the following circumstances:

1) Topography, right-of-way or other geographic conditions impose an economic hardship on the applicant and an equivalent alternative that can accomplish the same design objective is available.

- 2) A minor change to a standard is required to address a specific design or construction problem which, if not enacted, will result in undue hardship to the applicant.
- 3) A county road standard does not apply to a specific situation.

XVIII. CONSTRUCTION PLANS

A. General

- 1) Complete plans for all proposed roadway improvements within or impacting public right-of-ways and county easements shall be submitted to the Department of Public Works for approval. Such plans shall be prepared under the supervision of and stamped by a Registered Professional Engineer licensed to practice in the State of Oregon. No road, bridge, drainage or utility construction shall begin prior to County approval and issuance of a construction permit.
- 2) Submittal requirements consist of design plans, drainage calculations, erosion control plans (where applicable), and other information as required by the County Engineer.

B. Construction Plan Set Format

- 1) Plans shall be submitted on sheets 24 inches x 36 inches.
- 2) Plans shall have a vicinity map showing surrounding roads/streets, including existing and proposed roads/streets.
- 3) Plans shall have a north arrow, generally pointing to the top or right side of the plans.
- 4) The location and elevation of a United States Geological Survey, State Highway, or Polk County bench mark shall be shown. No other datum shall be used without permission of the County Surveyor. Temporary bench marks shall be shown on the plan.
- 5) The scale shall be 1 inch = 10 feet, 20 feet, 40 feet, 50 feet or 100 feet horizontally and 1 inch = 2 feet, 4 feet, 5 feet or 10 feet vertically.
- 6) The title block shall appear on each sheet of the plan set and shall be placed in the lower right hand corner of the sheet, across the bottom edge of the sheet or across the right hand edge of the sheet. The title block shall include the name of the project; the name, address and phone number of the engineering firm; the date of the plan set; the sheet title; and the sheet number.
- 7) The stamp of the Registered Professional Engineer responsible for preparation of the plans shall appear on each sheet.

C. Plan View - The plan view shall include the following:

- 1) Stationing shall run from left to right on plans and profile.

- 2) Stationing shall commence (usually 0+00) at the south or west end of project and end at the north or east end of project.
- 3) Right-of-way, property, and easement lines.
- 4) Subdivision name, tax lot numbers, street names and other identifying features. Street names are subject to approval by the Director of Community Development.
- 5) Location and stationing of existing and proposed road centerlines and curb faces.
- 6) Horizontal curve data of road centerlines and curb returns.
- 7) Location of all utilities within the limits of construction or affected by the construction.
- 8) Location, stationing, and size of drainage facilities. Drainage facility stationing shall be located in relation to the road stationing for all culverts, manholes, or other facilities.
- 9) Match lines with sheet number references.
- 10) Sidewalk ramp locations. Catch basins shall be located to avoid interfering with ramps.
- 11) Centerline stationing of all intersecting roads.
- 12) Location and description of existing survey monuments, including but not limited to section corners, quarter corners, and Donation Land Claim corners.
- 13) Include legend.
- 14) Where cut or fill slopes extend outside of the right-of-way, slope easements are required. Easements shall extend one foot outside of the toe of the slope and be shown on the plans.
- 15) All existing and proposed utility locations. New utilities in public right-of-ways shall comply with the locations shown on Standard Drawings 0001 through 0004 and 007A.

D. Profile View - The plan profile shall include the following:

- 1) Existing ground along proposed centerline.
- 2) Vertical alignment of proposed roads.
- 3) Stationing, elevations, vertical curve data, and slopes for center of road. For offset or superelevated cross sections, both top of curbs shall be shown. Where curbs are not to be constructed, ditch inverts shall also be shown.

- 4) Centerline of existing roads for a distance of at least 300 feet each way at intersections with proposed streets.
- 5) Extension of the profile of roads that will be extended in the future. The extended profile shall be at least 200 feet for local and minor collector roads and as required for major collector roads. The design shall be compatible with the constraints of the terrain.
- 6) All proposed drainage facilities, their types, all invert and top elevations, slopes, materials, bedding and backfill.
- 7) Existing drainage facilities that affect the design, e.g. downstream restrictions that back water on to the project site.
- 8) All existing and proposed sanitary and storm lines crossing the profile.

E. Other Requirements

- 1) Plans shall show a typical section of all road/street sections and/or channel improvements.
- 2) General notes shall be consolidated on a single page to avoid unnecessary repetition.
- 3) All traffic control (temporary protection and control of traffic), road/street signs, and pavement markings shall be shown on plans. Cost of traffic control, signs and pavement markings, and installation shall be the responsibility of the construction agent.
- 4) Boundaries of the involved drainage basins, with topographic features and drainage facilities, shall be shown if required by the County Engineer. Such plans shall include a map outlining the drainage basin boundaries for which a storm water runoff system is being designed and those adjacent basins which may be affected. This drainage basin map shall show the existing and proposed drainage facilities, including the ultimate receiving swale, stream or body of water. The scale of this map may vary from 1 inch equals 200 feet to 1 inch equals 2,000 feet, depending on the size of the drainage basins. Indicate ownership of all private property that will be affected by the change in drainage basin characteristics.
- 5) Drainage calculations shall be presented in a clear, concise and complete manner. These calculations shall address all runoff into the drainage system. Areas contributing flow to each inlet shall be computed separately and each inlet with contributing area shall be designated and shown on an accompanying contour map work sheet. Forms such as the ODOT Culvert Design Sheet may be used.
- 6) Structural construction plans and the associated calculations shall be submitted for proposed structures that include but are not limited to bridges, box culverts, and retaining walls. If computer software is used to determine structure size and placement, then sufficient supporting data shall be provided to understand and validate the software calculations.

- 7) Design assumptions and data such as road classification, design speed, superelevation, time of concentration, and ADT shall be provided.

F. Submittal

- 1) All plans, calculations and variances submitted for review and approval shall be accompanied by a completed Checklist for Engineering Plan Review (Appendix 2) and the required fees. The design review fee is 1 percent of the County Engineer's Estimate.
- 2) The first submittal shall consist of two sets of complete plans (plan, profile, and detail sheets) and one set of hydraulic, foundation and other project related tests, findings, or calculations. A list of variances from the County road standards shall also be submitted. The Department of Public Works will review the first submittal and make the required revisions on a first-in, first-out basis.
- 3) Upon completion of a detailed county review, the county will return one set of plans with "Red Line" comments and calculations to the applicant. After the applicant has completed all revisions, three (3) revised sets of plans and the original "Red Line" shall be returned to the county for approval. If approved, one (1) set of plans will be stamped approved by the county and returned to the applicant. The plan review and approval is valid for two (2) years from the date of the approval stamp. A request for extension shall be submitted to the County Department of Public Works.
- 4) Any design changes made after final approval shall be approved in writing by the Public Works Department prior to construction.
- 5) Prior to beginning construction, construction permits shall be obtained from the Department of Public Works and the required fees shall be paid. The construction permit fee shall be either 5 percent of the Engineer's Estimate or Force Account basis (labor, equipment, testing) as determined by the County Engineer.

G. Pre-Construction Conference - At the discretion of the Director of Public Works, a pre-construction conference may be required. The conference shall include representatives of the following groups:

- 1) Construction Agent
- 2) Contractor
- 3) Polk County Department of Public Works
- 4) Utilities
- 5) Other groups involved in the project

H. Project Final Inspection - Within one (1) week of notification that a project has been completed, the County Engineer shall conduct an initial inspection of the project and note deficiencies (if any). A punch list of deficiencies shall be provided to the contractor for correction. Upon notification that punch list deficiencies have been corrected, the County Engineer shall re-inspect the project. The County Engineer shall notify the contractor concerning the acceptability of the corrections. If

corrections are not acceptable, the County Engineer will again provide notice of deficiencies. This process shall continue until all deficiencies are corrected.

I. As-Built Submittal - Following completion of construction and correction of punch list deficiencies, the construction agent shall submit one (1) set of as-built drawings for preliminary review by the Department of Public Works. Drawings shall describe any and all revisions to the previously approved construction plans. If this submittal is not acceptable, the County shall give the construction agent notice of what is required for re-submittal. If the submittal is acceptable, the construction agent shall then submit two (2) paper sets of final as-built drawings. County may request final as-built drawings on 3 mil (minimum) thickness mylar or a print of contrast quality suitable for reproducing in lieu of paper copies. The construction agent shall also submit a computer version of the as-built drawings which is compatible with AutoCAD, R13 or higher.

J. Project Acceptance - Only after all project deficiencies are corrected and approved as-built drawings have been received shall the County issue an "Acceptance of Completion" letter. This letter shall also state the warranty period. The Public Works Director shall set the warranty period. The warranty period will typically range from 12 to 36 months from the "Acceptance of Completion" letter, based on the likelihood of construction defects. At the close of the warranty period, the construction agent shall receive a letter of "Final Acceptance of Completion". Note: This letter of "Final Acceptance of Completion" refers only to satisfactory construction of the project to County standards. Acceptance of such facilities into the Polk County Road System requires approval from the Polk County Board of Commissioners.

XIX. REFERENCE STANDARDS & SPECIFICATIONS

- A. Bridge Standards - *"Standard Specifications for Highway Bridges with ODOT Supplements"*, 1996 edition published by American Association of State Highway and Transportation Officials (AASHTO).
- B. Comprehensive Plan - *Polk County Comprehensive Plan*, (1995)
- C. Geometric Design Standards - *"A Policy on Geometric Design of Highways and Streets"*, 1994 edition published by American Association of State Highway and Transportation Officials (AASHTO)
- D. Hydraulics Manual - *"Hydraulics Manual"*, 1990 edition published by Oregon Department of Transportation (ODOT)
- E. Local Improvement Ordinance - *Polk County Local Improvements Ordinance Chapters 30, 31, 32, 35, 36*
- F. ODOT Standards - *"Highway Design Manual"*, 1993 edition published by Oregon Department of Transportation (ODOT).
- G. Roadside Design Standards - *"Roadside Design Guide"*, 1989 edition published by American Association of State Highway and Transportation Officials (AASHTO).

- H. Standard Specifications - *"Standard Specifications for Highway Construction"*, 1996 edition published by Oregon Department of Transportation (ODOT)
- I. Subdivision Ordinance - *Chapter 91, Polk County Code: Polk County Subdivision and Partition Ordinance.*
- J. Traffic Control Standards - *"Manual on Uniform Traffic Control Devices"*, 1988 edition published by U.S. Department of Transportation.
- K. Standard Specifications - *"Standard Specifications for Public Works Projects"*, 1990 edition published by the Oregon Association of Public Works.
- L. *"Standard Drawings for Design and Construction"*, published by Oregon Department of Transportation (ODOT)
- M. *"Construction Manual"*, 1991 edition with changes published by Oregon Department of Transportation (ODOT)
- N. *"Guide for Design of Pavement Structures"*, 1993 edition published by AASHTO.
- O. *"Traffic Practices Handbook for Local Roads and Streets in Oregon"*, 1996 edition published by Oregon Department of Transportation (ODOT).
- P. *"Principles of Construction of Hot-Mix Asphalt Pavements"*, Asphalt Institute, Manual Series No. 22, January, 1983.
- Q. *"Polk County Transportation Systems Plan"*, July 7, 1998.

APPENDIX 1

CHECKLIST FOR PRELIMINARY SUBDIVISION/PARTITION REVIEW

Name of Subdivision/Partition _____

Date _____ Reviewed By _____

- 1. Is inside or outside an urban growth boundary (UGB)?
- 2. If inside a UGB, is it in a sewer or water district?
- 3. Are permits or approvals from other government agencies required? If so, what type?

4. Streets and Roads:

- A. Existing county road or other public right-of-way (R/W)?
 - 1) Classification
 - 2) Is additional R/W required?
 - 3) Is it a gravel road that must be paved?
 - a) Along frontage of subdivision?
 - b) Off-site to connect to a paved county road?
 - 4) Is widening of existing pavement required?
 - 5) Are curb and sidewalks required?
 - 6) Access:
 - a) New streets and roads:
 - 1. Does spacing meet minimum standards?
 - 2. Is sight distance adequate?
 - b) Driveways for individual lots:
 - 1. Are locations available that have adequate sight distance?
 - 2. Are combined or joint-use driveways required?
 - 3. Is a limited access street involved?
- B. New Streets and Roads:
 - 1) Will they be public or private?
 - a) Public or private R/W?
 - b) Type of maintenance?
 - 1. County? (must be public R/W and built to county standards)
 - 2. Private? Homeowners Association required?
 - 2) Classification
 - 3) Required R/W width
 - 4) Required pavement width
 - 5) Are curb and sidewalks required?
 - 6) Curve radii - do they meet standards?
 - a) Horizontal curves
 - b) Curb return or pavement flares
 - c) Intersections
 - 7) Grades - does it appear that standards can be met?
 - 8) Will future street extensions be needed to serve adjoining property?
 - 9) Are one-foot reserve strips needed?

- 10) Are there existing easements that must be cleared before county can accept R/W dedication?
- 5. Drainage:
 - A. Where does runoff currently go? Does it remain within the existing drainageway?
 - B. Is there an existing public facility or natural drainage course nearby that can serve the property?
 - C. What and where is the ultimate receiving swale, stream or body of water? Is it located on the subject property?
 - D. Do existing facilities need improvement, enlargement or re-routing?
 - E. Is a detention system required?
 - F. Are there special or unusual problems?
 - 1) Is subdivision in a flood plain?
 - 2) Are existing storm drains too shallow?
 - 3) Does the ground slope so as to make it very difficult or impossible to get water into existing facilities or natural streams?
 - 4) Will solution to drainage problem require significant recision of street alignment or lot lines?
 - 5) Does a drainage plan need to be prepared and approved prior to the granting of detailed approval by the Hearings Officer or Planning Director?
 - G. Are special or unusual easements required?
- 6. Is the subdivision in a landslide hazard area?
 - A. Is a geologic study required?
- 7. If within a UGB, have the plans been reviewed and found acceptable by the affected city?

Notes: _____

APPENDIX 2

CHECKLIST FOR ENGINEERING PLAN REVIEW

Name of Subdivision/Partition _____

Date _____ Reviewed By _____

- 1. Vicinity map on cover sheet
- A. Is inside or outside an Urban Growth Boundary (UGB)?
- B. If inside a UGB, is it in a sewer or water district?
- 2. Title block
- 3. Engineers stamp and signature
- 4. Streets and roads
 - A. Design Speed
 - B. Typical sections
 - 1. Pavement
 - a) AC class
 - b) Thickness
 - c) Width
 - d) Cross-slope
 - 2. Aggregate base
 - a) Grading (1 inch-0, etc.)
 - b) Thickness
 - 3. Shoulder
 - a) Width - Narrower around cul-de-sac
 - b) Cross - slope
 - 4. Ditch
 - a) Depth from final grade at centerline
 - b) Foreslope
 - c) Backslope
 - 5. Curbs
 - a) Type
 - b) Height of exposure
 - c) Aggregate base underneath
 - d) Weep holes
 - 6. Sidewalks
 - a) Location (curb line or property line)
 - b) Width
 - c) Thickness of concrete
 - 7. Relocated utilities
 - a) Coordination with provider/owner
 - C. Profiles
 - 1. Stationing and scales (vertical and horizontal)
 - 2. Existing ground at centerline and right-of-way lines

- 3. Vertical alignment
 - a) Grades: Centerline for roadway, top of curb for curbed section
 - 1) Maximum
 - 2) Minimum (Including cul-de-sac and curb returns)
 - b) Vertical curves
 - 1) Minimum length
 - 2) Curve data (stations and elevations of PIVC, BVC, EVC)
- D. Plans
 - 1. North arrow, scale, street centerline, right-of-way lines, stationing, and street names
 - 2. Horizontal alignment
 - a) Curves
 - 1) Minimum radii
 - 2) Maximum superelevation
 - 3) Superelevation runoff
 - a. Minimum length
 - b. Method of obtaining
 - c. Shown on profile
 - 4) Curve data (radius, length, deflection angle, stations of P.C. & P.T.)
 - b. Cul-de-sac minimum radii
 - 1. Entering sac
 - 2. Around sac
 - c. Intersections
 - 1. Sight distances
 - 2. Angles
 - 3. Flare radii
 - 5) Curb returns
 - a. Radii
 - b. Wheelchair/Bicycle ramps
 - 3. Slope easements required
 - 4. Traffic signs and barricades
 - a) Shown on plans
 - b) Note that signs are to be furnished and installed by the construction agent.
 - 5. Note specifying that all utilities and utility laterals that will lie under the road shall be placed prior to paving of the road.
- E. Drainage
 - 1. Drainage basins and receiving facility, swale, stream or body of water shown
 - 2. Hydraulic calculations
 - a) Method applicable - Maximum area for rational formula
 - b) Parameters and assumptions
 - 3. Detention system required
 - a) Hydraulic calculations (method, parameters, assumptions)
 - b) Storage basin capacity
 - c) Method of flow restriction
 - 4. Existing stream or ditch to be piped - Maximum size

- 5. Provisions for draining adjacent property
- F. Pipe
 - 1. Diameter
 - 2. Type (concrete, steel, ADS)
 - 3. ASTM type and class
 - 4. Rubber gasket joints in roadway
 - 5. Crushed rock or cement slurry trench backfill in roadway
- G. Open channel
 - 1. New open channels not allowed in UGB
 - 2. Typical section
 - a) Width
 - b) Depth (also see profile)
 - c) Side slopes
- H. Profile
 - 1. Existing ground surface
 - 2. Finished ground surface
 - 3. Invert with elevations and slopes?
 - 4. Inlets, cleanouts, and manholes?
 - a) Location by station?
 - b) Elevation of inverts and rims
 - 5. Minimum or maximum cover over pipe
 - 6. Maximum depth in open channel
- I. Plan
 - 1. Alignment of pipe or ditch with ties to centerline, curb, right-of-way or property lines
 - 2. Location of inlets, cleanouts, and manholes
 - 3. Curved pipelines
 - a) Radius
 - b) Maximum joint stress
- J. Capacity? Free flow (not under head) in pipes
- K. Velocity
 - 1. Minimum for self-cleaning
 - 2. Maximum
 - a) Thrust blocks on pipe
 - b) Rip-rap or lining in ditches
- L. Inlets
 - 1. Type
 - 2. Type of grate
 - 3. Maximum spacing
 - 4. Maximum pipe size
 - 5. At all low points
 - 6. Maximum depth of catch basins
- M. Cleanouts, junction boxes, or manholes
 - 1. Required at:
 - a) Changes in alignment or grade

- b) Lateral connections if lateral pipe greater than one-half diameter of main line
- c) Changes in pipe size
- d) Maximum cleaning intervals
- 2. Manholes required because of pipe size or depth
- N. Outfalls: Rip-rap or structure to prevent erosion
- O. Conflicts with sewers or other facilities
- P. Easements over private property
 - 1. Minimum width
 - 2. Extra width required by pipe size, depth or special conditions
 - 3. Access to easement
- Q. Seeding and mulching

Notes: _____

APPENDIX 3

TRANSPORTATION IMPACT ANALYSIS CHECKLIST

Name of Development _____

Date _____ Reviewed By _____

- Engineer's stamp & signature
- Table of Contents
- Executive Summary
- Vicinity Map
- Development Description & Site Plan
- Description of Adjacent Parcels & Developments
- Description of Study Area
- Existing Traffic Volumes
- Accident Data
- Existing Performance of Transportation System
- Complete Trip Generation Data
- Trip Generation Figures for Development Affecting the Study Area
- Identification & Justification of Critical Analysis Period
- Trip Distribution
- Forecast Traffic Volumes Without Development
- Forecast Performance of Transportation System Without Development
- Forecast Traffic Volumes With Development
- Forecast Performance of Transportation System With Development
- Safety Analysis of Site Accesses
- Analysis of Applicable Warrants at Site Accesses
- Comparison of Proposed Access Spacing With Applicable Standards
- Analysis of Development Parking Needs
- Analysis of Turning Characteristics & Geometrics
- Analysis of Internal Vehicle & Pedestrian Circulation
- Analysis of Other Adverse/Controversial Impacts
- Analysis of Development Impacts on Pedestrian & Bicycle Needs
- Listing of Intersections Projected to Not Meet Standards
- Mitigation Description & Demonstration of Adequacy & Feasibility
- Copies of Raw Traffic Count Data
- Calculation Sheets & Software Output
- Applicable Warrant Worksheets

Notes: _____

APPENDIX 4

STANDARD DRAWINGS

<u>Drawing Number</u>	<u>Drawing Title</u>
0001	Typical Roadway Section for Major Collector Roads
0002	Typical Roadway Section for Minor Collector/Resource Roads (Paved)
0002A	Typical Roadway Section for Minor Collector/Resource Roads (Unpaved)
0003	Typical Roadway Section for Local Roads (Paved)
0004	Typical Roadway Section for Local Roads (Unpaved)
0005	Typical Roadway Section for Public Use Roads
0007	Typical Roadway Section for Urban Streets
0007A	Standard Utility Location for Urban Streets
0015	Standard Driveway With Culvert
0015A	Standard Driveway Without Culvert
0015B	Type 3 Driveway Access
0016	Curbed Driveway and Alley Approaches
0017	Curbs
0018	Sidewalks
0020	90 Degree Intersection for Major Collector and Above
0025	Cul-de-sac and Turn Around Layout
0030	Typical Backfill and Pipe Zone Section
0031A	Standard Catch Basin Details: Type 1 Catch Basin and Clean Out
0031B	Standard Catch Basin Details: Type 2 (Side Inlet) Catch Basin
0031C	Standard Catch Basin Details: Type 3 Catch Basin: Frame and Gate
0033	Typical Parking Strip
0037	Storm Water Standard Precast Manholes
0038	Storm Water Detention
0039	Subgrade and Spring Catchment Drains
0040	Typical Road Sections
0041	Monument Box Insertion
0042	Permanent Barricade

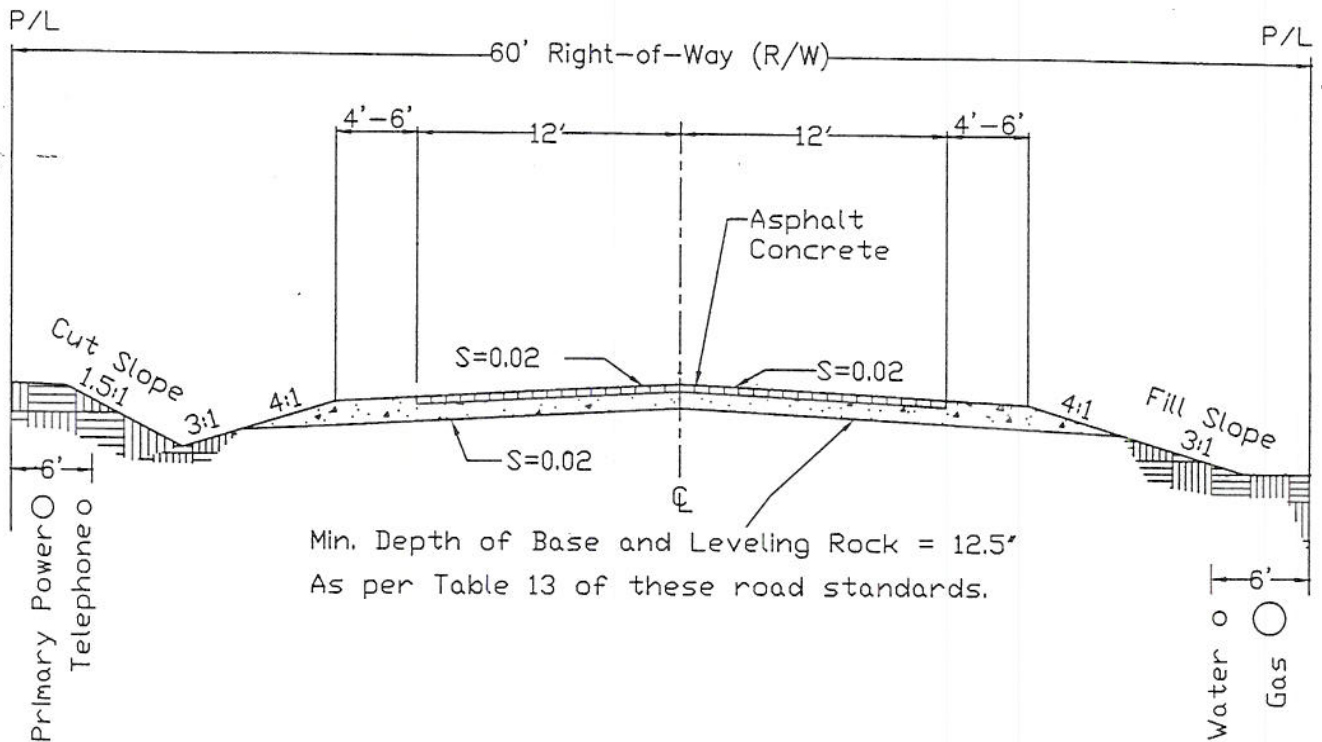

Notes:

1. Materials and construction shall conform to the Polk County Road Standards. □□□□ Standard Specifications for Highway Construction and the appropriate details may be used to supplement these standards as approved by the Public Works Director.
2. Utilities may be placed in shoulder area if cut or fill slopes extend outside of R/W and if approved by Public Works.
3. Utility locations: telephone and power - south and west side; gas and water - north and east side. Locate as close to P/L as possible.
4. Minimum cover for all utilities is 36".
5. Minimum thickness of asphalt concrete is 4" of Class B.
6. See Table 6 of these standards for road geometric standards.
7. County Engineer shall determine shoulder width. Slope of shoulder can vary from 2%-5%.
8. Standard ditch depth is 2' as measured from crown of roadway.

Approved Tony Snipes July 7, 1998
County Engineer Date

TYPICAL ROADWAY SECTION FOR MAJOR COLLECTOR

POLK COUNTY PUBLIC WORKS
751 SW CLAY ST.
DALLAS, OR 97338
503-623-9287

DRAWN BY: FCL CHECKED BY: TRS

DATE: June 1998 DRAWING NO: 0001

No	DESCRIPTION	DATE	BY	Appr

REVISION

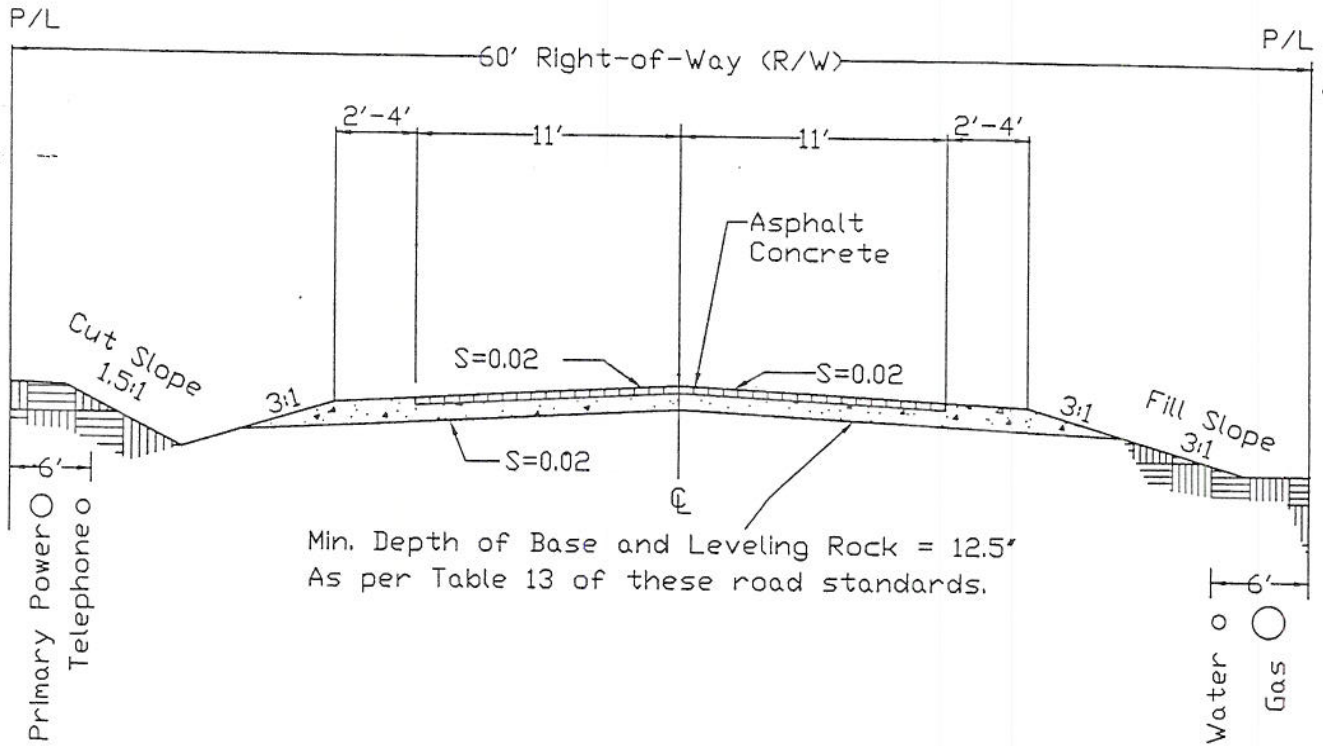

Notes:

1. Materials and construction shall conform to the Polk County Road Standards. DOT Standard Specifications for Highway Construction and the appropriate details may be used to supplement these standards as approved by the Public Works Director.
2. Utilities may be placed in shoulder area if cut or fill slopes extend outside of R/W and if approved by Public Works.
3. Utility locations: telephone and power - south and west side; gas and water - north and east side. Locate as close to P/L as possible.
4. Minimum cover for all utilities is 36".
5. Minimum thickness of asphalt concrete is 4" of Class B.
6. See Table 6 of these standards for road geometric standards.
7. County Engineer shall determine shoulder width. Slope of shoulder can vary from 2%-5%.
8. Standard ditch depth is 2' as measured from crown of roadway.

Approved Tony Snyder July 7, 1998
County Engineer Date

TYPICAL ROADWAY SECTION FOR
MINOR COLLECTOR/RESOURCE ROAD

POLK COUNTY PUBLIC WORKS
751 SW CLAY ST.
DALLAS, OR 97338
503-623-9287

DRAWN BY: FCL CHECKED BY: TRS

DATE: June 1998 DRAWING NO: 0002

No	DESCRIPTION	DATE	BY	Appr

REVISION

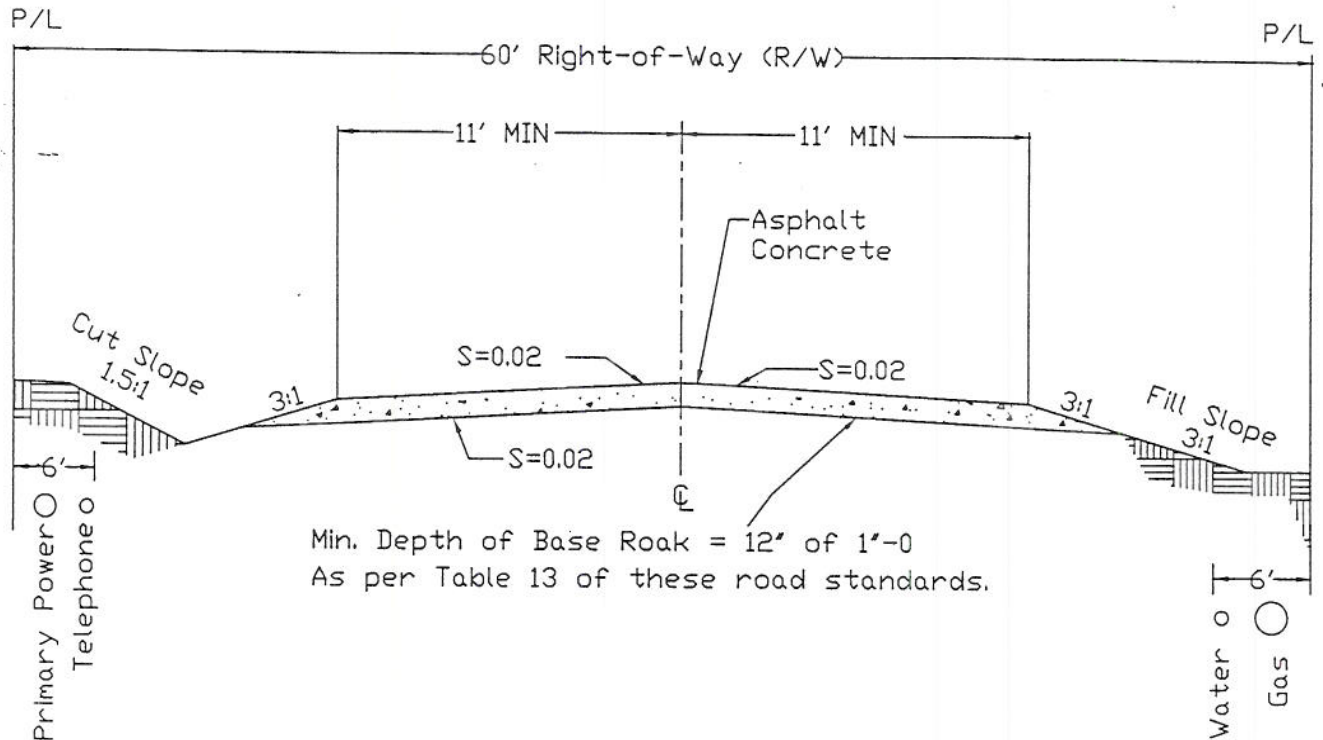

Notes:

1. Materials and construction shall conform to the Polk County Road Standards. DDOT Standard specifications for Highway Construction and the appropriate details may be used to supplement these standards as approved by the Public Works Director.
2. Utilities may be placed in shoulder area if cut or fill slopes extend outside of R/W and if approved by Public Works.
3. Utility locations: telephone and power - south and west side; gas and water - north and east side. Locate as close to P/L as possible.
4. Minimum cover for all utilities is 36".
5. See Table 6 of these standards for road geometric standards.
6. County Engineer shall determine shoulder width. Slope of shoulder can vary from 2%-5%.
7. Standard ditch depth is 2' as measured from crown of roadway.
8. Cross slopes for gravel roads shall be 0.03- 0.05 ft/ft

Approved Jerry Smiles July 7, 1998
 County Engineer Date

TYPICAL ROADWAY SECTION FOR MINOR/RESOURCE COLLECTOR

POLK COUNTY PUBLIC WORKS
 751 SW CLAY ST.
 DALLAS, OR 97338
 503-623-9287

No	DESCRIPTION	DATE	BY	Appr
REVISION				

DRAWN BY: FCL	CHECKED BY: TRS
DATE: June 1998	DRAWING NO: 0002A

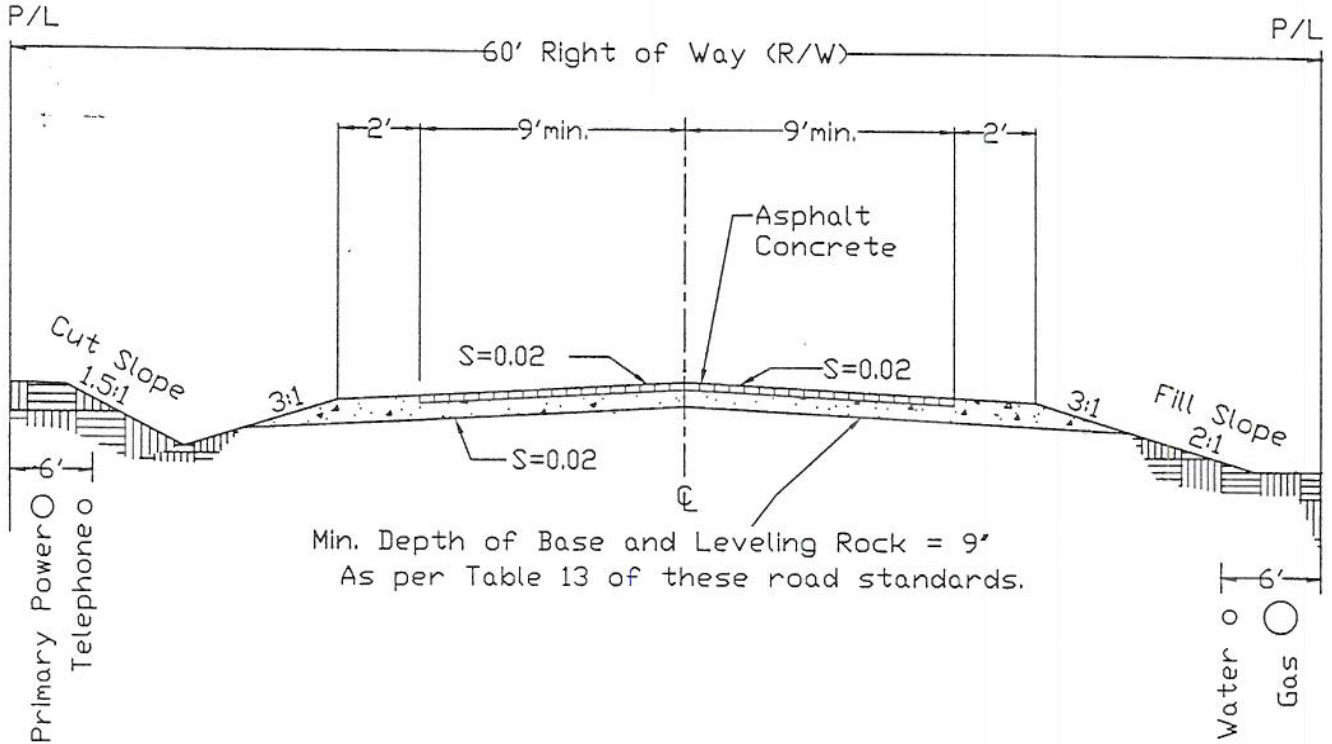

Notes:

1. Materials and construction shall conform to the Polk County Road Standards. ODOT Standard Specifications for Highway Construction and the appropriate details may be used to supplement these standards as approved by the Public Works Director.
2. Utilities may be placed in shoulder area if cut or fill slopes extend outside of R/W and if approved by Public Works.
3. Utility locations: telephone and power - south and west side; gas and water - north and east side. Locate as close to P/L as possible.
4. Minimum cover for all utilities is 36".
5. Minimum thickness of asphalt concrete is 2.5" of Class B.
6. See Table 6 of these standards for road geometric standards.
7. County Engineer shall determine shoulder width. Slope of shoulder can vary from 2%-5%.
8. Standard ditch depth is 2' as measured from crown of roadway.

Approved Jonny Smyler July 7, 1998
County Engineer Date

TYPICAL ROADWAY SECTION FOR
LOCAL (PAVED) ROAD

POLK COUNTY PUBLIC WORKS
751 SW CLAY ST.
DALLAS, OR 97338
503-623-9287

No	DESCRIPTION	DATE	BY	Appr
REVISION				

DRAWN BY: FCL	CHECKED BY: TRS
DATE: June 1998	DRAWING NO: 0003

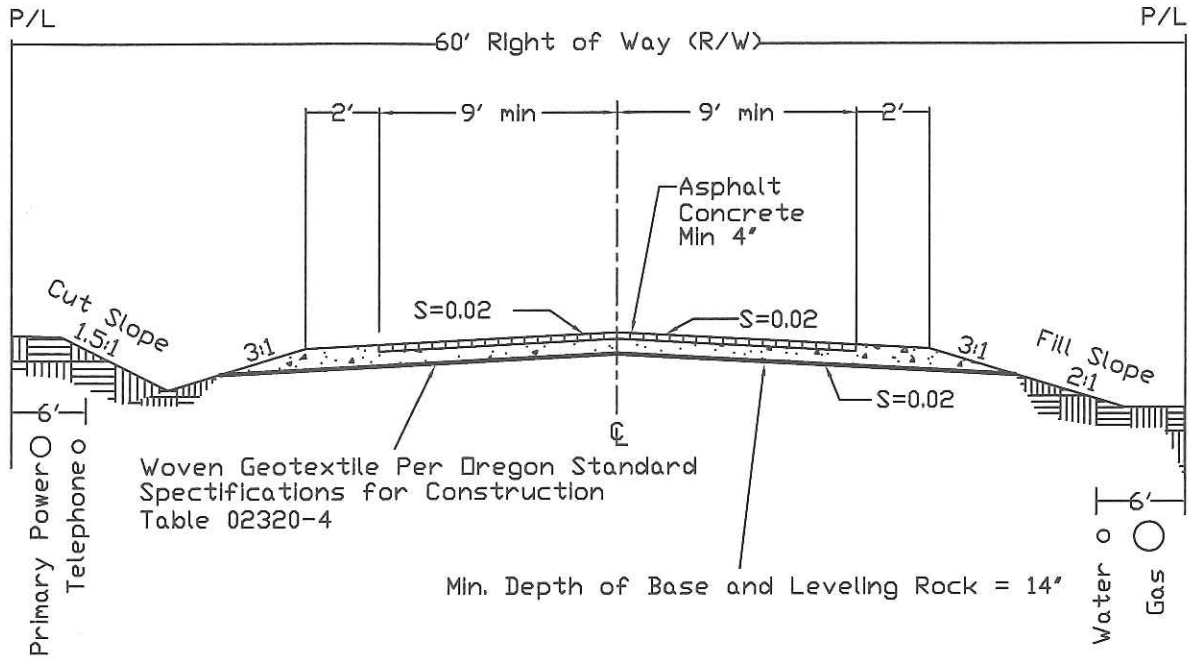

Notes:

1. Materials and construction shall conform to the Polk County Road Standards, Oregon Standard Specifications for Construction (2015) and the appropriate details may be used to supplement these standards as approved by the Public Works Director.
2. Utilities may be placed in shoulder area if cut or fill slopes extend outside of R/W and if approved by Public Works.
3. Utility locations: telephone and power - south and west side; gas and water - north and east side. Locate as close to P/L as possible.
4. Minimum cover for all utilities is 36".
5. Use appropriate geotextile based on existing soil types.
6. See Table 6 of these standards for road geometric standards.
7. County Engineer shall determine shoulder width. Slope of shoulder can vary from 2%-5%.
8. Standard ditch depth is 2' as measured from crown of roadway.

Approved  9/29/15
 County Engineer Date

TYPICAL ROADWAY SECTION FOR
 LOCAL (PAVED) ROAD
 ON EXPANSIVE SOILS

POLK COUNTY PUBLIC WORKS
 820 SW ASH ST.
 DALLAS, OR 97338
 503-623-9287

DRAWN BY: FCL	CHECKED BY: TBW
DATE: Sept 2015	DRAWING NO: 0003A

No	DESCRIPTION	DATE	BY	Appr
REVISION				

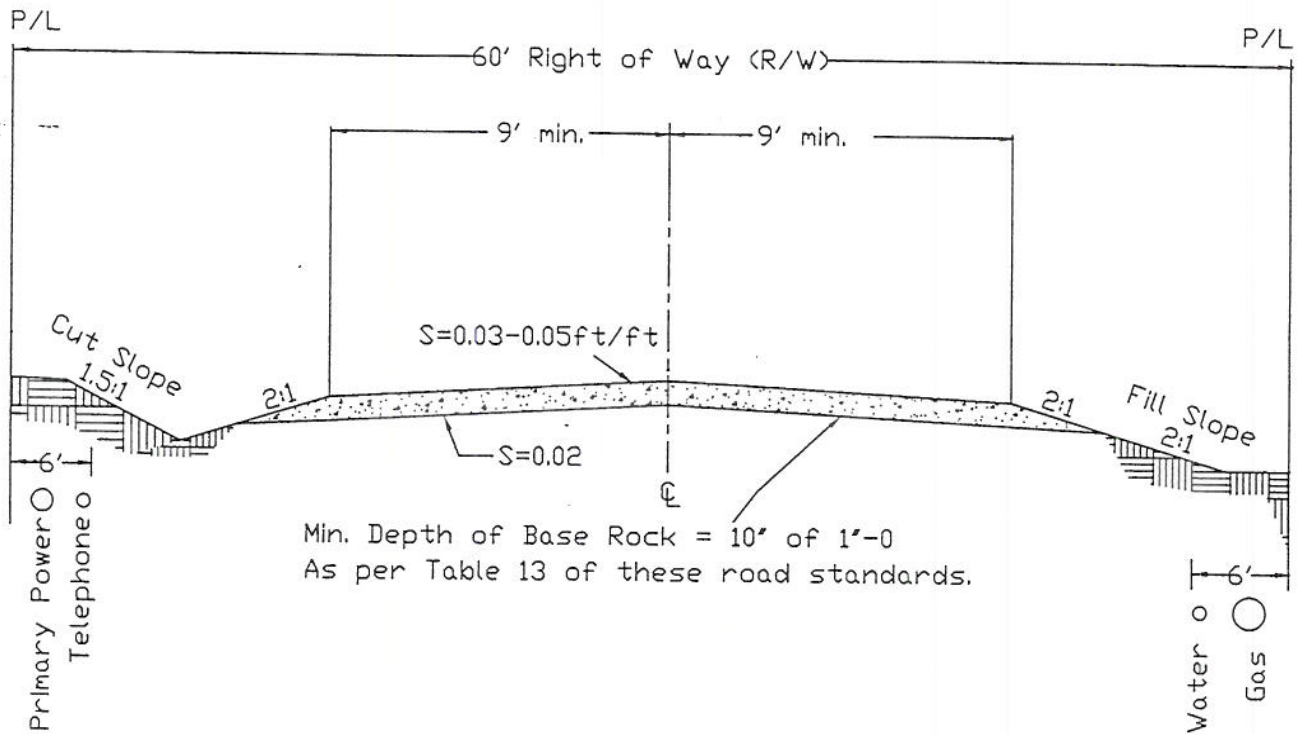

Notes:

1. Materials and construction shall conform to the Polk County Road Standards, ODOT Standard Specifications for Highway Construction and the appropriate details may be used to supplement these standards as approved by the Public Works Director.
2. Utilities may be placed in shoulder area if cut or fill slopes extend outside of R/W and if approved by Public Works.
3. Utility locations: telephone and power - south and west side; gas and water - north and east side. Locate as close to P/L as possible.
4. Minimum cover for all utilities is 36".
5. See Table 6 of these standards for road geometric standards.
6. County Engineer shall determine shoulder width. Slope of shoulder can vary from 2%-5%.
7. Standard ditch depth is 2' as measured from crown of roadway.
8. Cross slopes for gravel roads shall be 0.03 - 0.05 ft/ft.

Approved Jerry Snyder July 7, 1998
County Engineer Date

TYPICAL ROADWAY SECTION FOR
LOCAL (UNPAVED) ROAD

POLK COUNTY PUBLIC WORKS
751 SW CLAY ST.
DALLAS, OR 97338
503-623-9287

DRAWN BY:	FCL	CHECKED BY:	TRS
DATE:	June 1998	DRAWING NO:	0004

No	DESCRIPTION	DATE	BY	Appr

REVISION

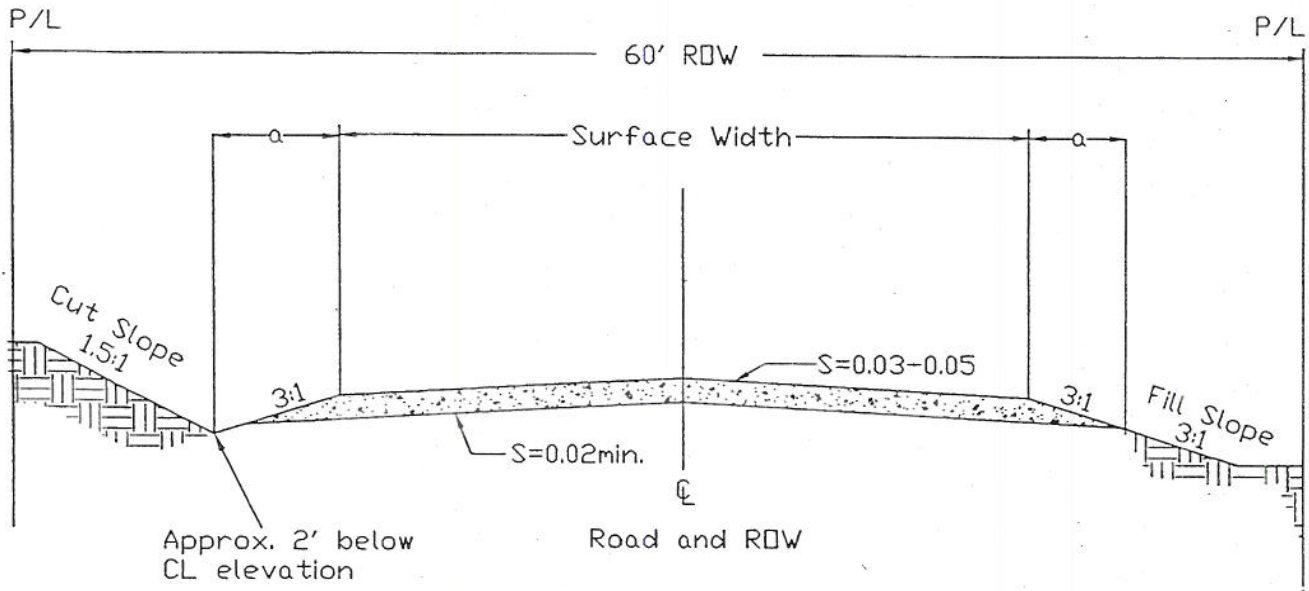

Notes:

1. Surface width and crushed rock thickness shall conform to the following: Standards unless otherwise specified by County Engineer:

Number of Dwellings Served	Surface Width (Feet)	1'-0" Crushed Rock Thickness (Inches)
Two or fewer	12	6
More than two	16	8

2. a = Distance from edge of roadway to line perpendicular to bottom of ditch. Typical distance is between 5' and 8'.
3. Utilities shall be located as shown on Typical Section for Local (Unpaved) Road (Polk County Standard Drawing No. 0004).
4. There shall be a turnaround at the end of a dead end public use road. Turnarounds can be circular, "L" shaped or "T" shaped. See Standard Drawing No. 0025
5. See Table 6 of these standards for road geometric standards.
6. Min. radius of horizontal curve is 205'.
7. Standard ditch depth is 2' as measured from crown of roadway.
8. If an extension to a public use road is longer than 500', then a 10' wide by 40' long turnout shall be provided.

Approved Jerry Snyder 8/20/98
County Engineer Date

TYPICAL ROADWAY SECTION FOR PUBLIC USE ROAD

POLK COUNTY PUBLIC WORKS
751 SW CLAY ST.
DALLAS, OR 97338
503-623-9287

No	DESCRIPTION	DATE	BY	Appr
1	Change surface width vs. dwellings	8-20-98	FCL	TRS

DRAWN BY: FCL	CHECKED BY: TRS
DATE: August 1998	DRAWING NO: 0005

REVISION

STANDARD CROSS SECTION

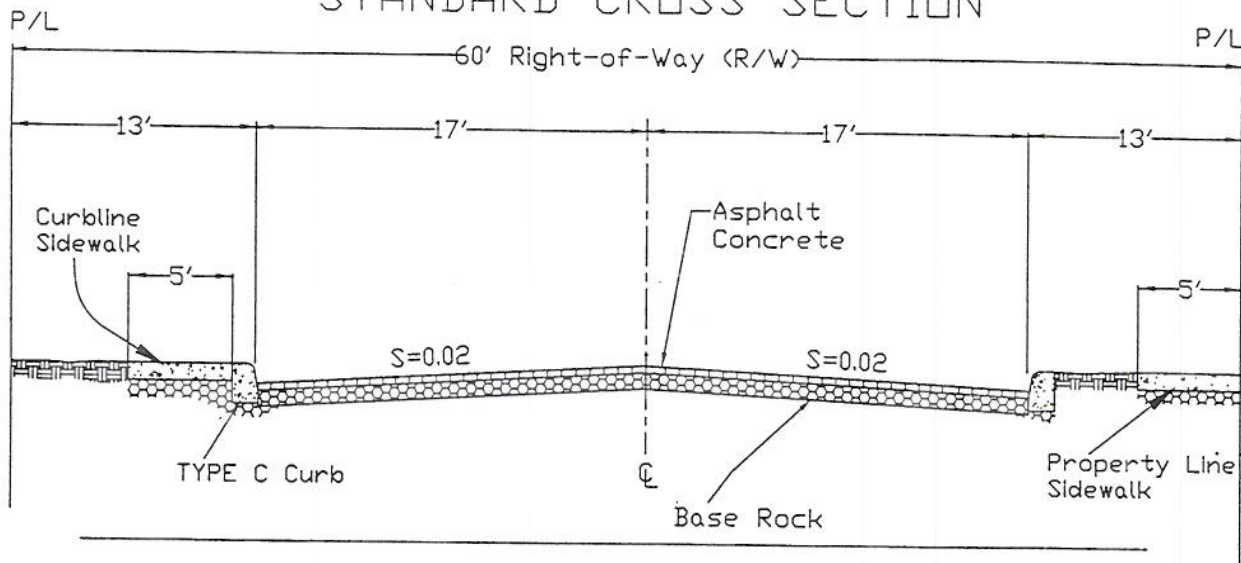

TILTED CROSS SECTION

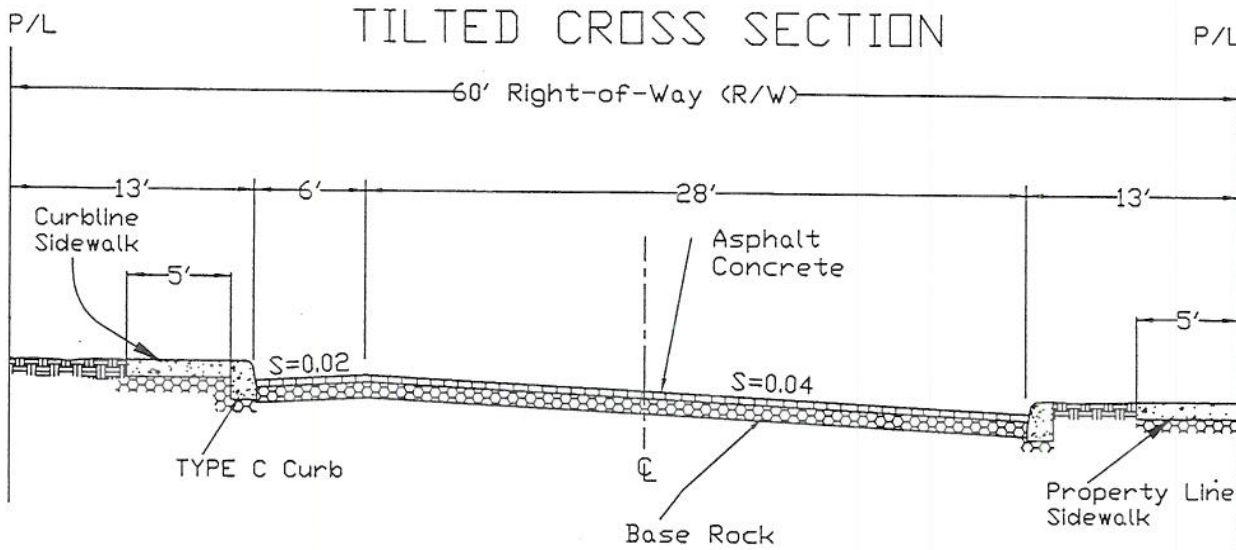

Notes:

1. Materials and construction shall conform to the Polk County Road Standards. ODOT Standard Specifications for Highway Construction and the appropriate details may be used to supplement these standards as approved by the Public Works Director.
2. See Standard Drawing 0007A for utility locations.
3. Minimum thickness of asphalt concrete is 2 1/2" of Class B or Class C for local roads.
4. See Table 13 of these road standards for paving and base thickness.
5. Curb shall be either a Type B or Type C curb with a 6" exposure for local roads. Arterials and collectors shall have 7" exposure.
6. Curb and sidewalk shall have a minimum base of 2" of 1'-0" crushed rock.
7. Concrete for curb and sidewalk shall be commercial mix (3000 psi - 28 day min).
8. Tilted street requires approval by the County Engineer.

Approved Amy R. Snyder 6-30-98
County Engineer Date

TYPICAL ROADWAY SECTION FOR URBAN STREET	
POLK COUNTY PUBLIC WORKS 751 SW CLAY ST. DALLAS, OR 97338 503-623-9287	
DRAWN BY: FCL	CHECKED BY: TRS
DATE: June 1998	DRAWING NO: 0007

No	DESCRIPTION	DATE	BY	Appr
REVISION				

CURB LINE SIDEWALK

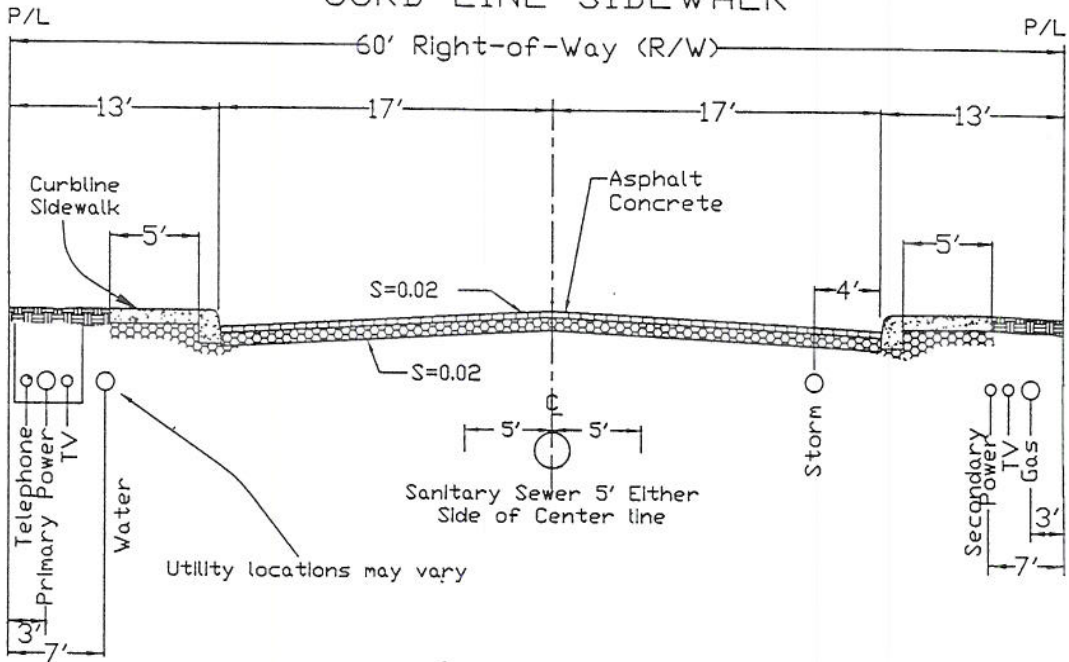

PROPERTY LINE SIDEWALK

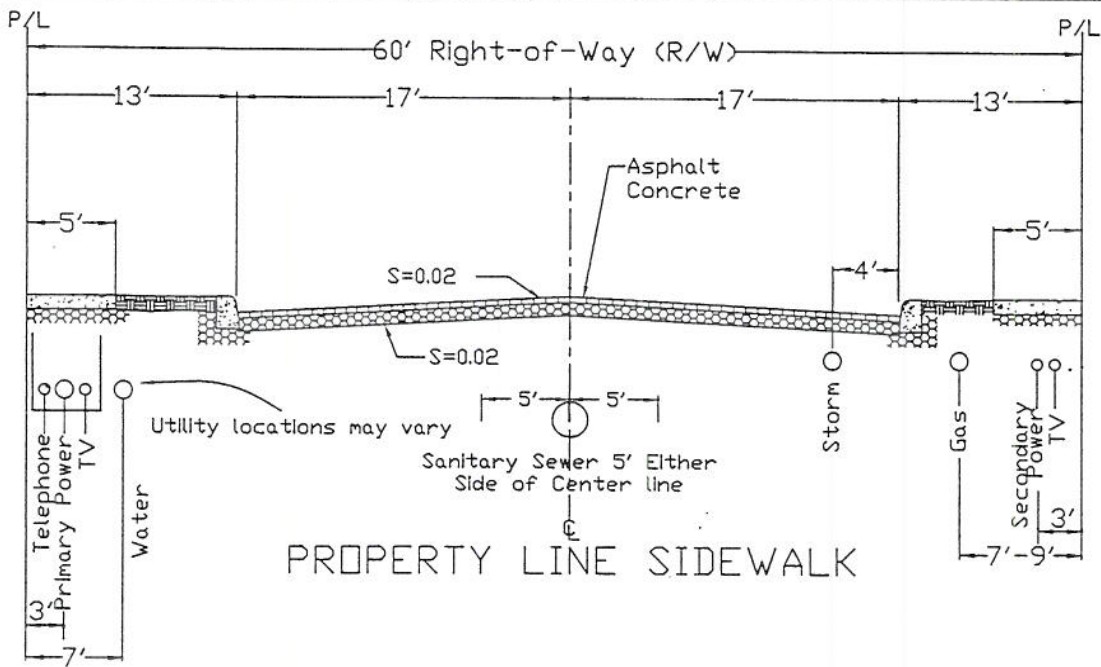

NOTES:

1. Minimum cover for all utilities is 36".
2. All utilities or utility conduits shall be installed before streets are paved.
3. County Engineer shall approve all pavement cuts in existing streets.
4. Utility locations: tel and power - south and west side; gas and water - north and east side. Locate as close to P/L as possible.

Approved *Tony Snyder* 6-30-98
County Engineer Date

STANDARD UTILITY LOCATION
FOR URBAN STREETS

POLK COUNTY PUBLIC WORKS
751 SW CLAY ST.
DALLAS, OR 97338
503-623-9287

DRAWN BY: FCL CHECKED BY: TRS

DATE: June 1998 DRAWING NO: 0007A

No	DESCRIPTION	DATE	BY	Appr

REVISION

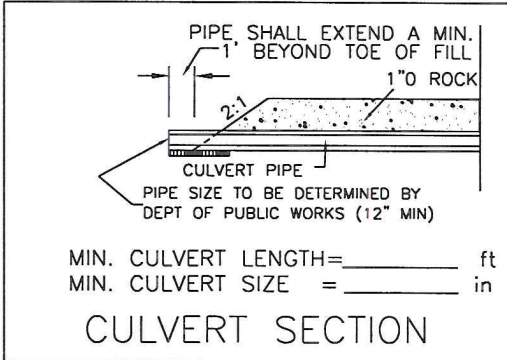
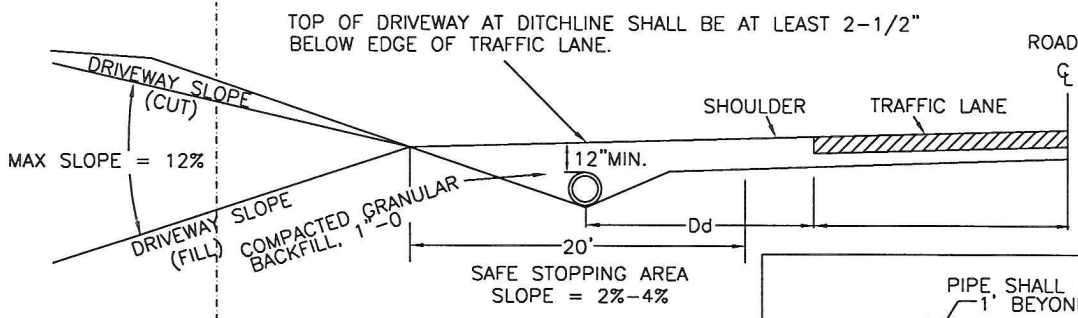
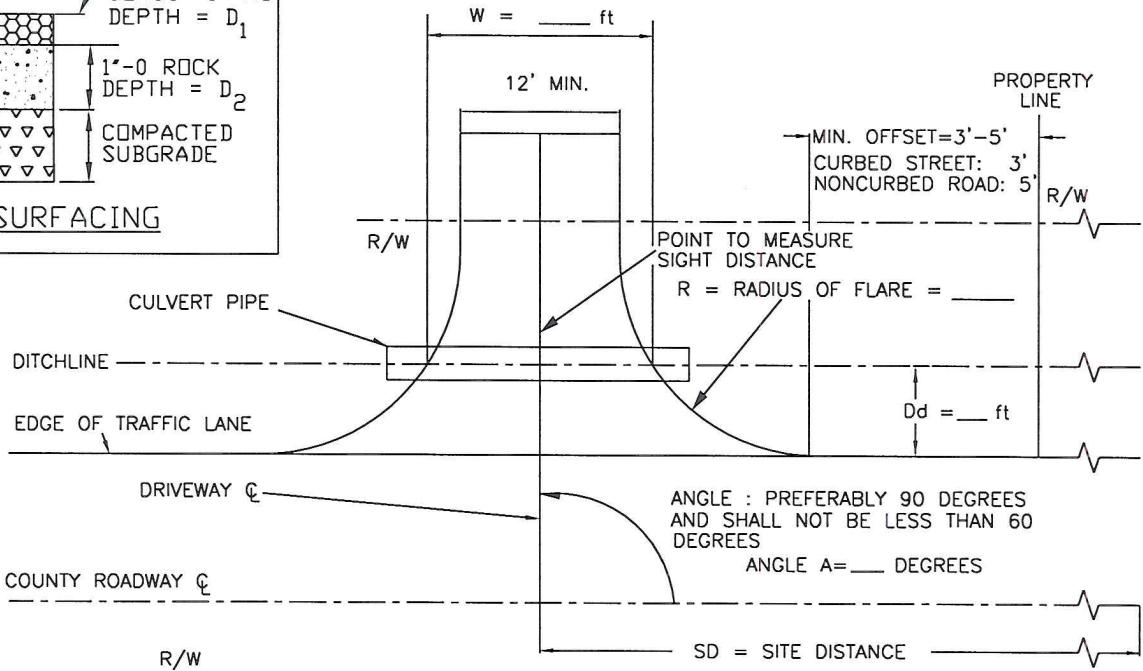
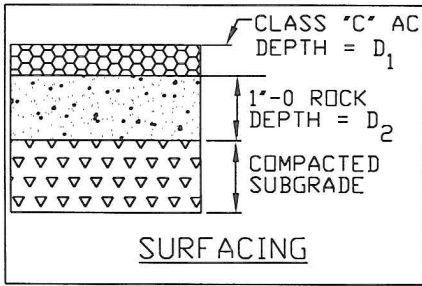

NOTES:

1. WIDTH "W" AND FLARE RADIUS "R" SHALL BE AS FOLLOWS:
 RESIDENTIAL 12-24' 10'-20'
 COMMERCIAL 20'-40' 20'-35'
2. MINIMUM CULVERT DIAMETER IF NEEDED IS 12", UNLESS APPROVED BY THE COUNTY ENGINEER.
3. MINIMUM COVER OVER CULVERT IS 12" UNLESS APPROVED BY THE COUNTY ENGINEER.
4. CLEAN DITCHLINE 20' ABOVE AND BELOW ACCESS IN ORDER TO ENSURE DRAINAGE.
5. PIPE TO BE LAID AT EXISTING GRADE OF DITCH.
6. REMOVE VEGETATION AND/OR EMBANKMENT ON BOTH SIDES OF ACCESS TO ENSURE REQUIRED SIGHT DISTANCE (SD).
 REQUIRED SD: LEFT _____ RIGHT _____
7. CONTACT PUBLIC WORKS FOR PROJECT INSPECTION PRIOR TO PLACING ASPHALT CONCRETE.
8. ASPHALT CONCRETE DEPTH D¹, AS SPECIFIED IN SPECIAL PROVISIONS.
9. 1"-0 CRUSHED AGGREGATE D², AS SPECIFIED IN SPECIAL PROVISIONS.

Approved *[Signature]* 8/8/12
 County Engineer Date

STANDARD DRIVEWAY WITH OPEN DRAINAGE

POLK COUNTY PUBLIC WORKS
 820 SW ASH ST.
 DALLAS, OR 97338
 503-623-9287

DRAWN BY: FCL CHECKED BY: TBW
 DATE: NOVEMBER 2011 DRAWING NO: 0015

No	DESCRIPTION	DATE	BY	APPR.
1	Consolidate permit instructions	Nov 2011	FCL	TBW

REVISION

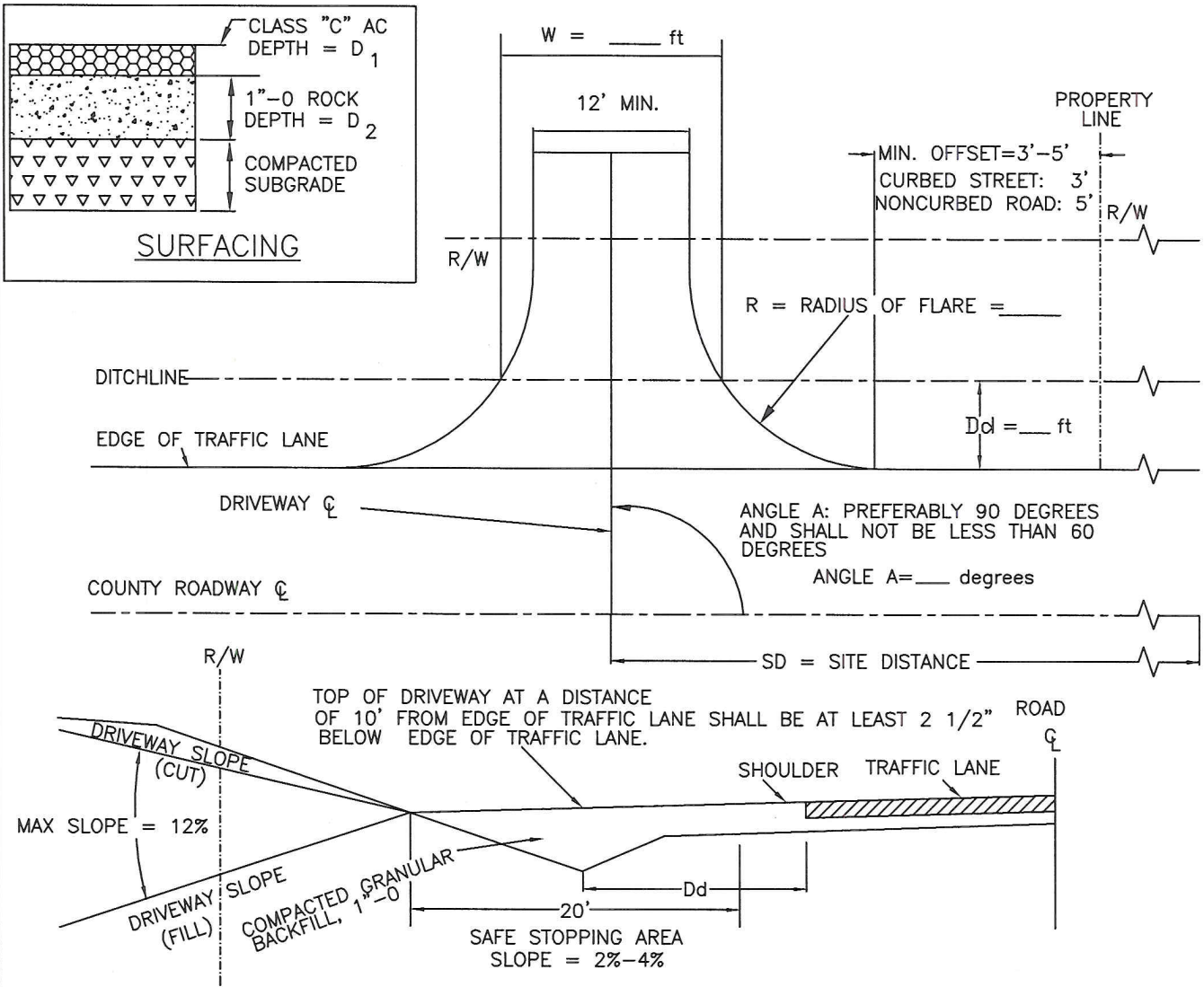

NOTES:

1. WIDTH "W" AND FLARE RADIUS "R" SHALL BE AS FOLLOWS:
RESIDENTIAL 12-24' 10'-20'
COMMERCIAL 20'-40' 20'-35'
2. CLEAN DITCHLINE 20' ABOVE AND BELOW ACCESS IN ORDER TO ENSURE DRAINAGE.
3. REMOVE VEGETATION AND/OR EMBANKMENT ON BOTH SIDES OF ACCESS TO ENSURE REQUIRED SIGH DISTANCE (SD).
REQUIRED. SD: LEFT _____ RIGHT _____
4. CONTACT PUBLIC WORKS FOR PROJECT INSPECTION PRIOR TO PLACING ASPHALT CONCRETE.
5. ASPHALT CONCRETE DEPTH D_1 , AS SPECIFIED IN SPECIAL PROVISIONS.
6. 1"-0 CRUSHED AGGREGATE D_2 , AS SPECIFIED IN SPECIAL PROVISIONS.

Approved  8/8/12
County Engineer Date

DRIVEWAY WITH OPEN DRAINAGE	
POLK COUNTY PUBLIC WORKS 820 SW ASH ST. DALLAS, OR 97338 503-623-9287	
DRAWN BY: FCL	CHECKED BY: TBW
DATE: NOVEMBER 2011	DRAWING NO: 0015A

No	DESCRIPTION	DATE	BY	APPR.
1	Consolidate permit instructions	Nov 2011	FCL	
REVISION				

TYPE 3 DRIVEWAY ACCESS CONSTRUCTION REQUIREMENTS

DIMENSIONS: $W =$ _____ (ft) $D r/w =$ _____ (ft)
 $A =$ _____ (degrees/angles) $Dd =$ _____ (ft)
 $R1 =$ _____ (ft) $R2 =$ _____ (ft)

DRIVEWAY SURFACE: Asphalt concrete pavement
 Class: C or B
 Compacted Thickness: 4" (in)

LEVELING SURFACE: Size: 3/4"-0
 Compacted Thickness: 4"

BASE ROCK: Size: 1 1/2"-0
 Compacted Thickness: Varies

CULVERT PIPE: [] Required [] Not required
 Type _____
 Diameter _____ (in)
 Length _____ (ft)

PLAN & SECTION VIEWS

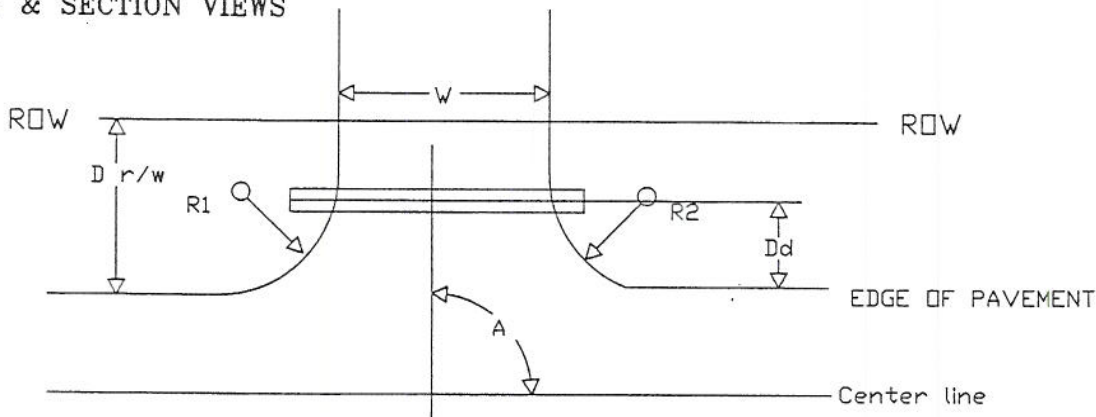

Conform to adjoining roadway

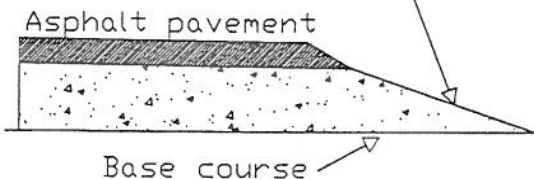

Approved Jonny R Snyder 6-30-98
 County Engineer Date

TYPE 3 DRIVEWAY ACCESS

POLK COUNTY PUBLIC WORKS
 751 SW CLAY ST.
 DALLAS, OR 97338
 503-623-9287

No	DESCRIPTION	DATE	BY	Appr

DRAWN BY: FCL	CHECKED BY: TRS
DATE: June 1998	DRAWING NO: 0015B

REVISION

W = ____ (ft) DRIVEWAY WIDTH AT THE RIGHT-OF-WAY LINE MEASURED PARALLEL TO THE CENTERLINE OF THE ROADWAY.
 RESIDENTIAL 12' - 24'
 COMMERCIAL 24' - 35'

S = ____ (ft) SETBACK WIDTH (DISTANCE BETWEEN CURB AND SIDEWALK)

SW = ____ (ft) SIDEWALK WIDTH

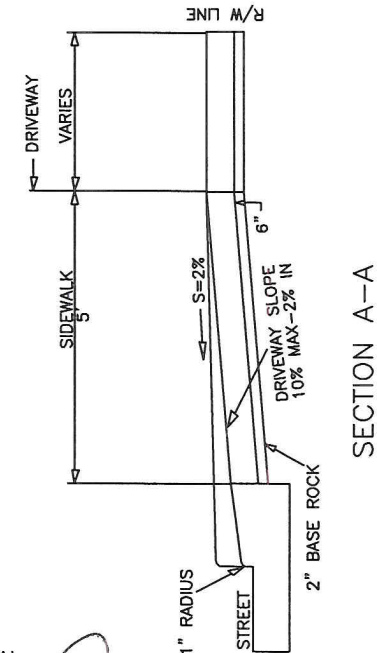
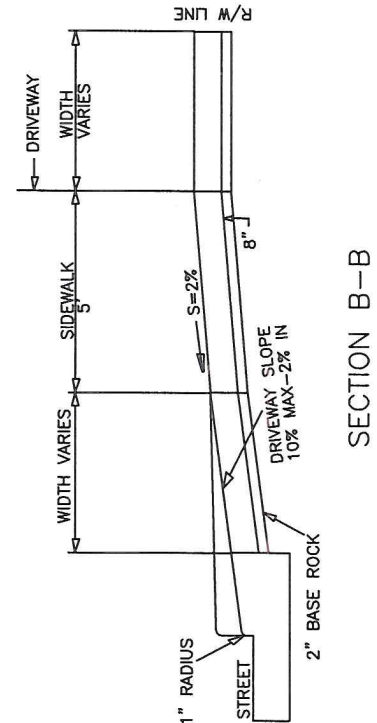
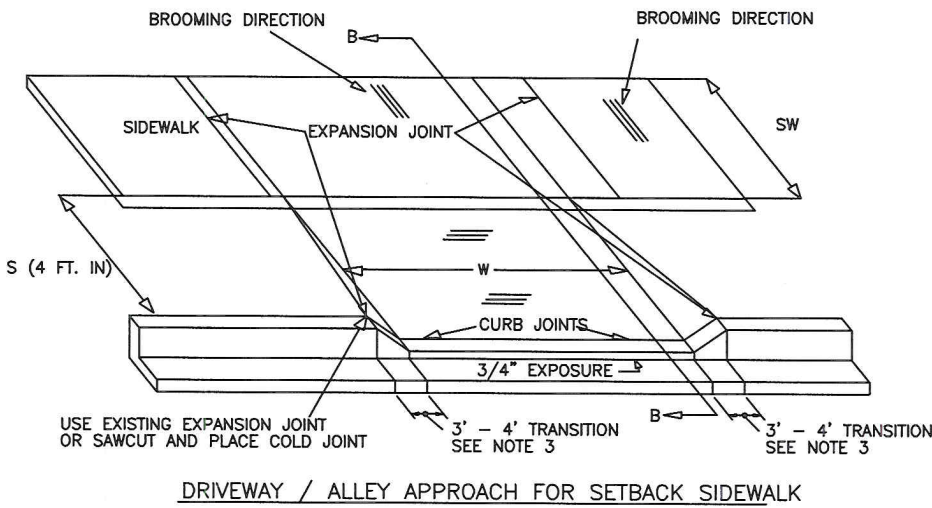
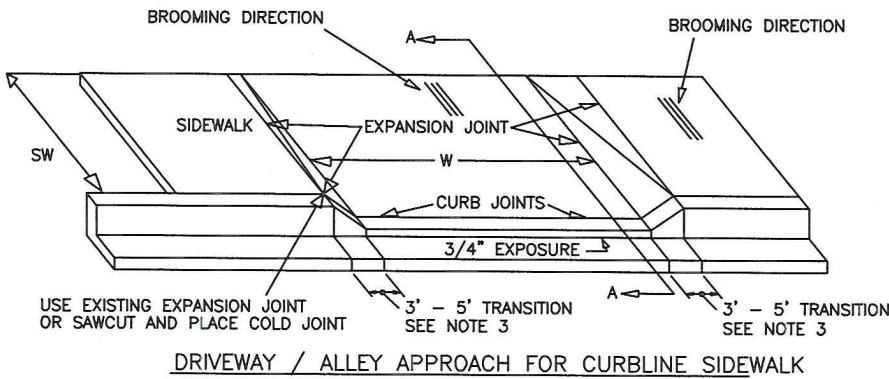

NOTES

1. RESIDENTIAL DRIVEWAYS AND SIDEWALK SECTIONS THROUGH DRIVEWAYS SHALL HAVE A NOMINAL THICKNESS OF 6" OF COMMERCIAL MIX.
2. CONCRETE FOR COMMERCIAL USE AND ALLEY APPROACHES SHALL HAVE A NOMINAL THICKNESS OF 8".
3. CURB TRANSITIONS FOR COMMERCIAL USE AND ALLEY APPROACHES SHALL BE 5 FEET.
4. BASE ROCK SHALL BE 3/4"-0 OR 1"-0.
5. SIDEWALKS INCLUDING THAT PORTION CROSSING THE DRIVEWAY SHALL HAVE TRANSVERSE CONTRACTION JOINTS AT 5 FOOT INTERVALS.
6. EXPANSION JOINTS SHALL BE 1/2" PREMOLDED ASPHALT IMPREGNATED MATERIAL OR EQUAL EXTENDING FROM SUBGRADE TO FINISHED GRADE.
7. CURB JOINT SHALL BE A TROWELED JOINT WITH A MINIMUM 1/2" RADIUS ALONG THE BACK OF CURB.

Approved: *[Signature]* 8/8/12
 County Engineer Date

No	DESCRIPTION	DATE	BY	APR
1	Consolidate permit instructions	Nov 2011	FCL	TBW

REVISION

DRIVEWAY WITH CLOSED DRAINAGE

POLK COUNTY PUBLIC WORKS
 820 SW ASH ST.
 DALLAS, OR 97338
 503-623-9287

DRAWN BY: FCL CHECKED BY: TBW
 DATE: November 2011 DRAWING NO: 0016

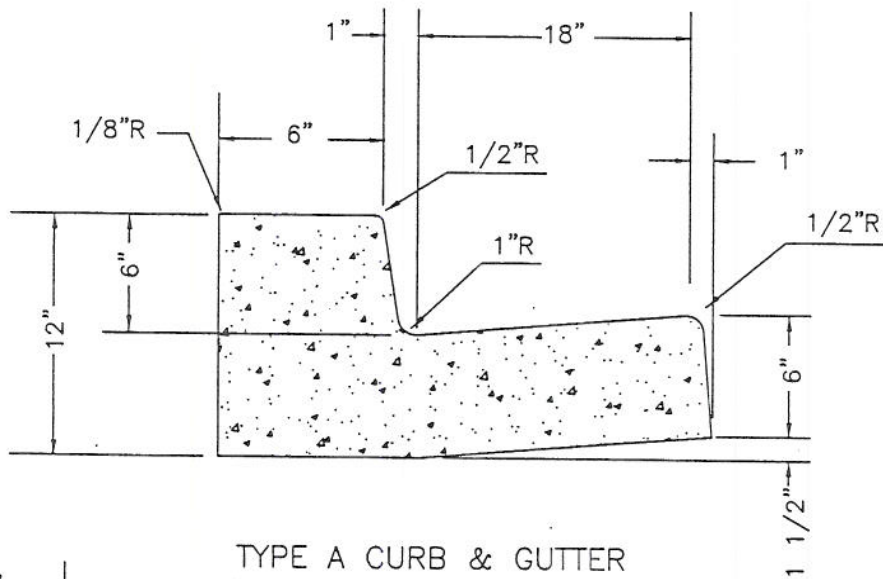

TYPE A CURB & GUTTER

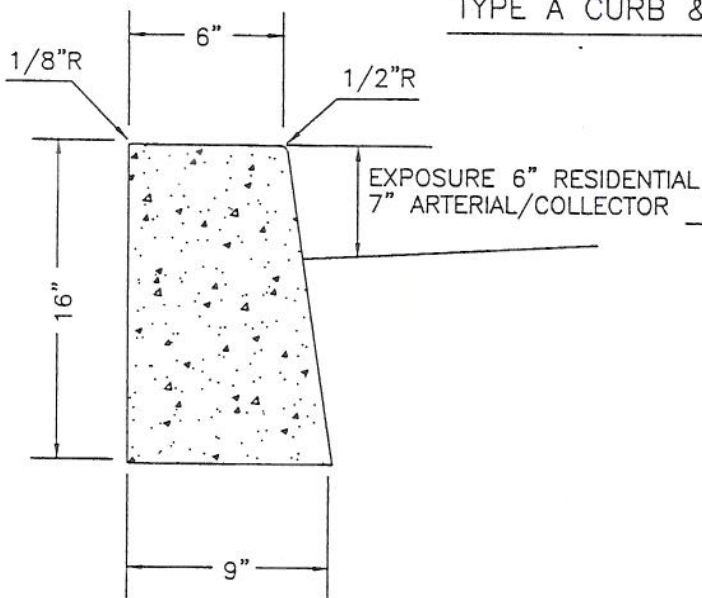

TYPE C CURB

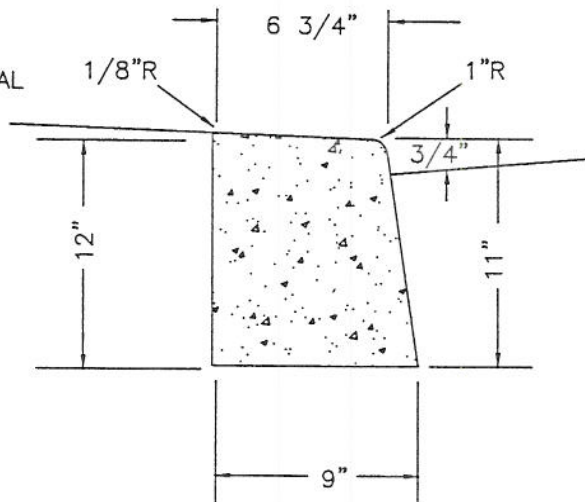

CURB AT DRIVEWAY

NOTES:

1. Curbs and gutters shown may be used with either A.C. or P.C.C. pavements.
2. Transitions from one type curb to another will be detailed on project plans as necessary.
3. "Tee-Bar" contraction joint to be installed every 15' of curb.
4. 3000 p.s.i. concrete to be used for all curbs (28 day).

CURB QUANTITIES CU. YD. PER LIN. FT.	
TYPE	QUANTITY
A	0.04942
C	0.03085

Approved Henry R. Snyder 6-30-98
County Engineer Date

CURBS	
POLK COUNTY PUBLIC WORKS 751 SW CLAY ST. DALLAS, OR 97338 503-623-9287	
DRAWN BY: FCL	CHECKED BY: TRS
DATE: June 1998	DRAWING NO: 0017

No	DESCRIPTION	DATE	BY	Appr

REVISION

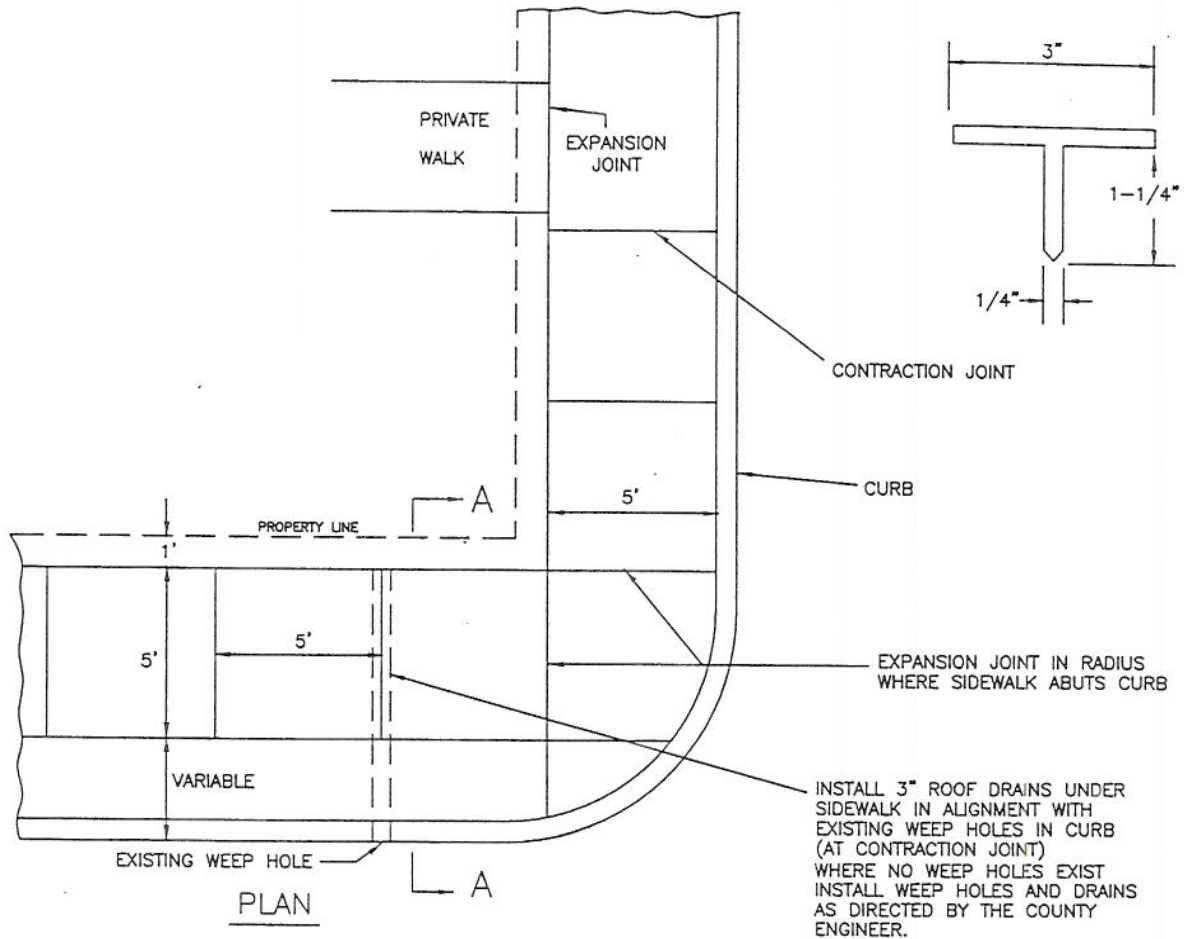

NOTES:

1. EXPANSION JOINTS 1/2" X 3-1/2" PREMOLDED JOINT FILLER MATERIAL SPACED 15' O.C. AND AT OTHER LOCATIONS SHOWN. PREMOLDED JOINT FILLER MATERIAL SHALL BE PLACED ON ALL EDGES OF UTILITY VAULTS OR STRUCTURES EXPOSED TO SIDEWALK. MATERIAL SHALL BE REGRESSED OR CUT TO WITHIN 1/2" OF THE FINISHED CONCRETE SURFACE.
2. CONTRACTION "TEE-BAR" JOINTS 1 1/4" DEEP, SPACED 5" O.C.
3. 3000 P.S.I. CONCRETE TO BE USED ON ALL SIDEWALKS.
4. APPROXIMATE QUANTITIES 0.01234 CU. YD. PER SQ. FT. OF 4' WALK
5. ALL PAVEMENT TURF OR PLANTED AREAS DISTURBED BY THE SIDEWALK CONSTRUCTION SHALL BE RESTORED TO THEIR ORIGINAL CONDITION.

CUT OR FILL SLOPE 2 HORIZ TO 1 VERT (OR FLATTER)
VERTICAL BANKS NOT PERMITTED.

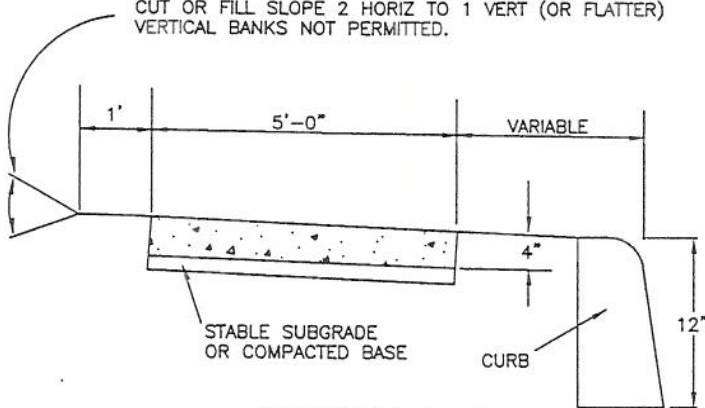

SECTION A-A

Approved Tommy R. Snyder 6-30-98
County Engineer Date

SIDEWALKS	
POLK COUNTY PUBLIC WORKS 751 SW CLAY ST. DALLAS, OR 97338 503-623-9287	
DRAWN BY: FCL	CHECKED BY: TRS
DATE: June 1998	DRAWING NO: 0018

No	DESCRIPTION	DATE	BY	Appr
REVISION				

SCALE: 1" = 20'

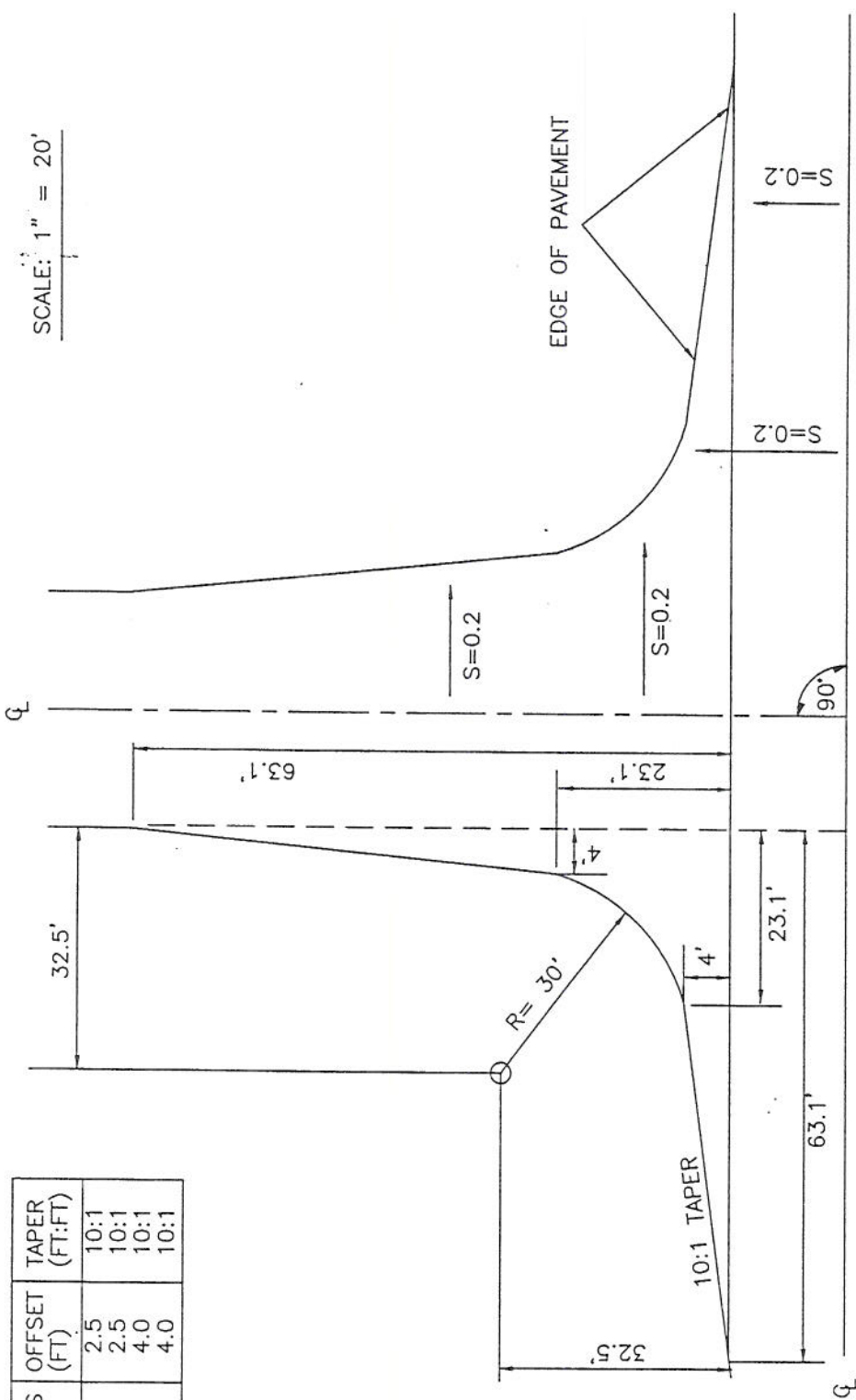

RADIUS (FT)	OFFSET (FT)	TAPER (FT:FT)
25	2.5	10:1
30	2.5	10:1
40	4.0	10:1
45	4.0	10:1

ARTERIAL OR MAJOR COLLECTOR

NOTES:

1. SIMPLE CURVES MAY BE USED IN THE DESIGN OF INTERSECTIONS FOR OTHER THAN ARTERIALS OR MAJOR COLLECTORS UNLESS OTHERWISE SPECIFIED BY THE COUNTY ENGINEER.

Approved Jonny R. Snyder 6-30-98
 County Engineer Date

90 DEGREE INTERSECTION FOR MAJOR COLLECTOR AND ABOVE
 POLK COUNTY PUBLIC WORKS
 751 SW CLAY ST.
 DALLAS, OR 97338
 503-623-9287

No	DESCRIPTION	DATE	BY	Appr
REVISION				

DRAWN BY: FCL	CHECKED BY: TRS
DATE: June 1998	DRAWING NO: 0020

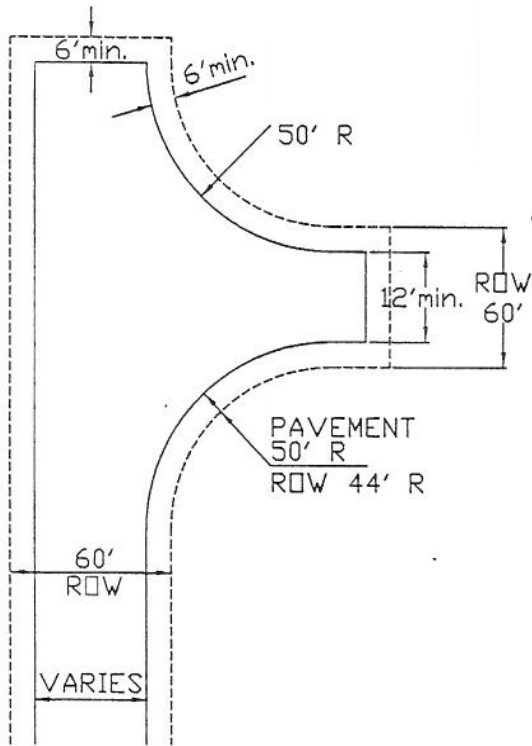

L - SHAPE

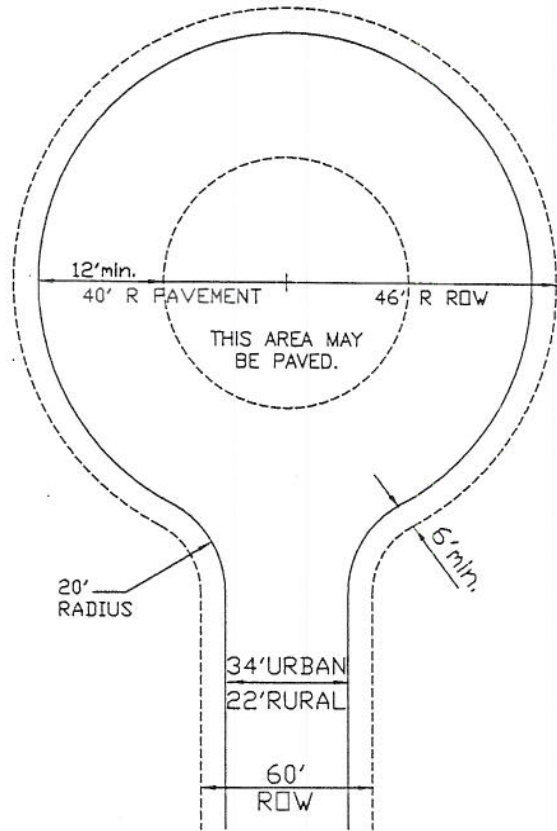

CUL-DE-SAC

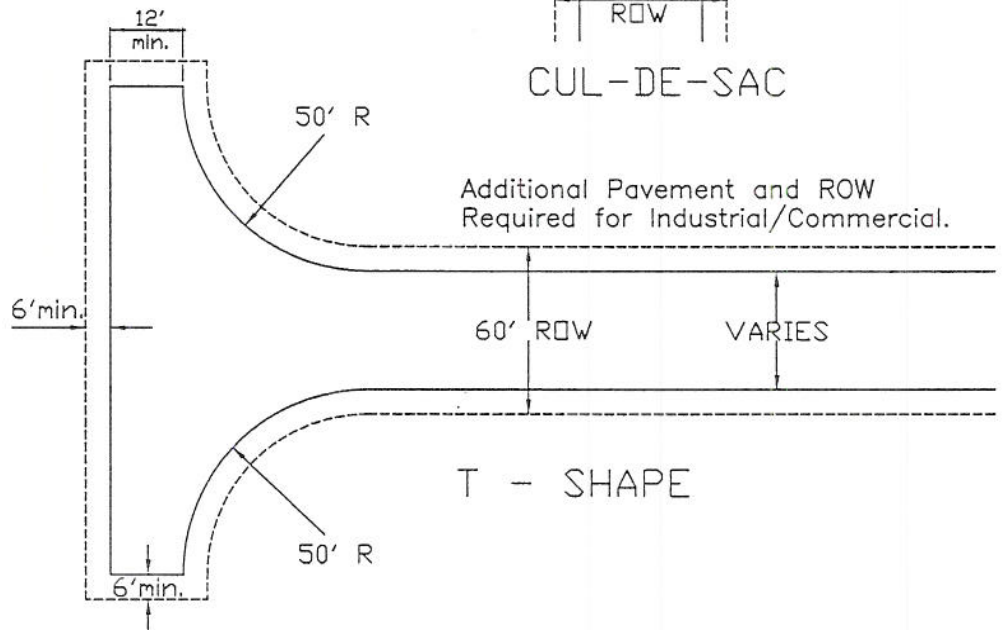

T - SHAPE

NOTES:

1. Cul de sac in industrial areas shall provide adequate turnarounds for the type of vehicles served by the streets.
2. Sidewalks shall be 5' wide. If required, measured from the face of curb to back of the sidewalk.

Approved Tommy R. Snyder 6-30-98
 County Engineer Date

No	DESCRIPTION	DATE	BY	Appr
REVISION				

CUL-DE-SAC AND TURN AROUND LAYOUT	
POLK COUNTY PUBLIC WORKS 751 SW CLAY ST. DALLAS, OR 97338 503-623-9287	
FCL	TRS
June 1998	0025

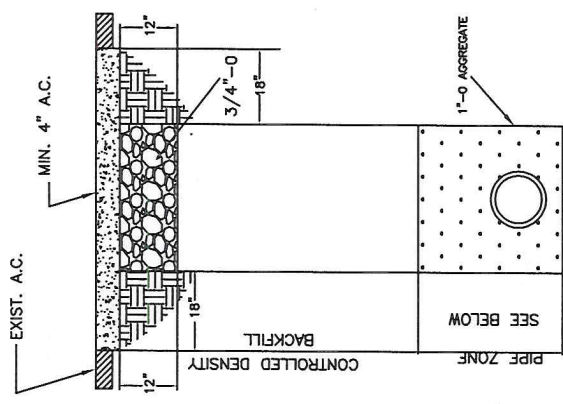

FOUNDATION STABILIZATION WITH 1"-0 AGGREGATE AS DIRECTED BY ENGINEER

CONTROLLED DENSITY BACKFILL

CONTROLLED DENSITY BACKFILL SHALL BE USED TO BACKFILL ALL EXISTING PAVED ROADS.

TRENCH PAY WIDTH

SIZE OF PIPE	SIZE OF PIPE
6" - 8"	24"
10" - 24"	OUTSIDE DIAMETER PLUS 18"
27" - 36"	OUTSIDE DIAMETER PLUS 24"
42" AND LARGER	OUTSIDE DIAMETER PLUS 30"

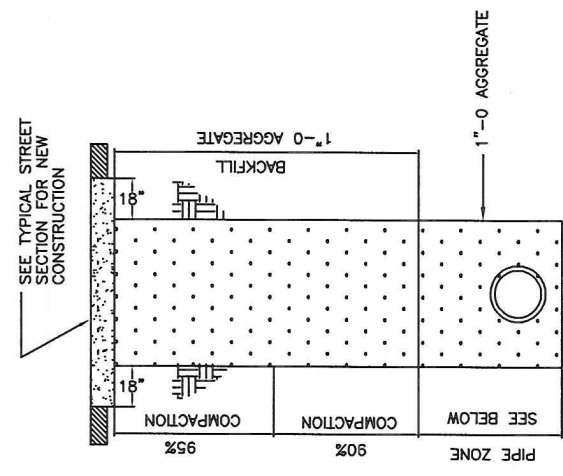

FOUNDATION STABILIZATION AS DIRECTED BY ENGINEER

GRANULAR BACKFILL

GRANULAR BACKFILL SHALL BE USED WITHIN THE ROADWAY, ROADWAY SECTION CONSISTS OF TRAFFIC LANES, SHOULDERS AND ASSOCIATED SLOPES.

*PAVEMENT REPLACEMENT WIDTH SHALL BE TRENCH WIDTH PLUS 18 INCHES ON EACH SIDE.

TRENCH PAY WIDTH

SIZE OF PIPE	SIZE OF PIPE
6" - 8"	24"
10" - 24"	OUTSIDE DIAMETER PLUS 18"
27" - 36"	OUTSIDE DIAMETER PLUS 24"
42" AND LARGER	OUTSIDE DIAMETER PLUS 30"

LEGEND

D_{in} INSIDE DIAMETER
 D_{out} OUTSIDE DIAMETER
 d DEPTH OF BEDDING BELOW PIPE

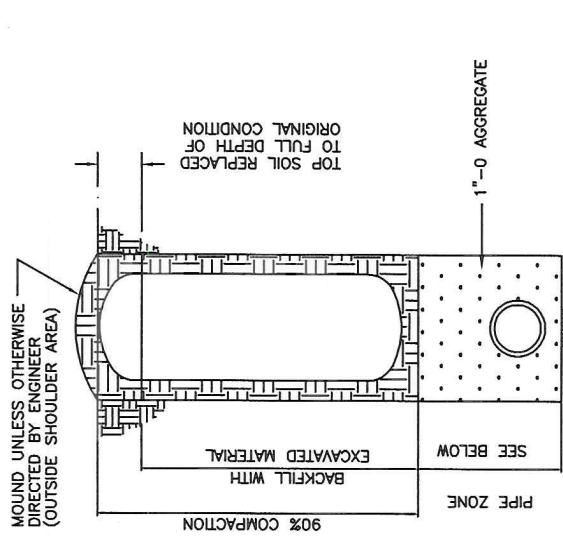

FOUNDATION STABILIZATION WITH 1"-0 AGGREGATE AS DIRECTED BY ENGINEER

NATIVE BACKFILL

TOP SOIL REPLACED TO FULL DEPTH OF ORIGINAL CONDITION

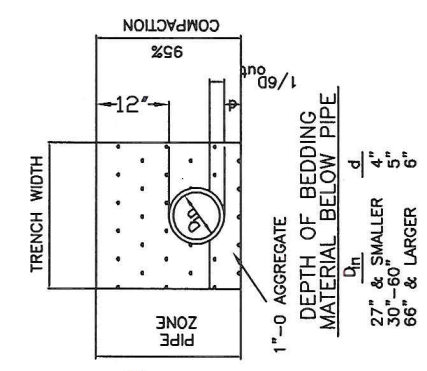

Approved: *[Signature]* 8/8/12
 County Engineer Date

TYPICAL BACKFILL AND PIPE ZONE SECTION	
POLK COUNTY PUBLIC WORKS 820 SW ASH ST DALLAS, OR 97338 503-623-9287	
DRAWN BY: FCL	CHECKED BY: TBW
DATE: March 2011	DRAWING NO: 0030

No	DESCRIPTION	DATE	BY	Appr
1	TRENCH PATCHING	7/12-99	BJL	TRS
2	CONTROLLED DENSITY BACKFILL T-CUT	3/03-11	RDR	TBW
REVISION				

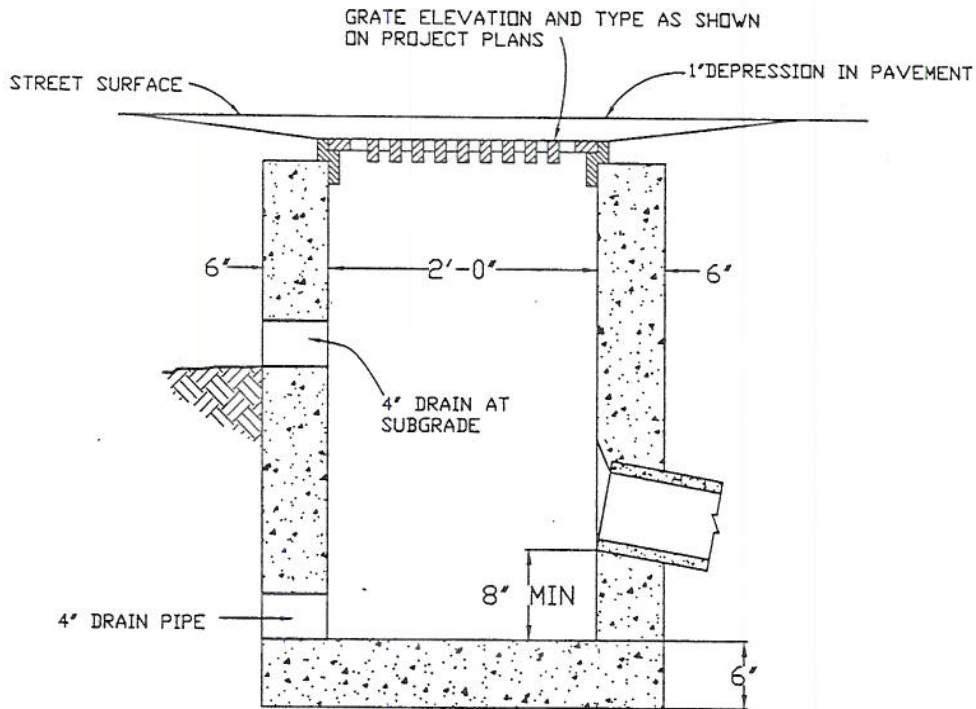

SECTION A-A

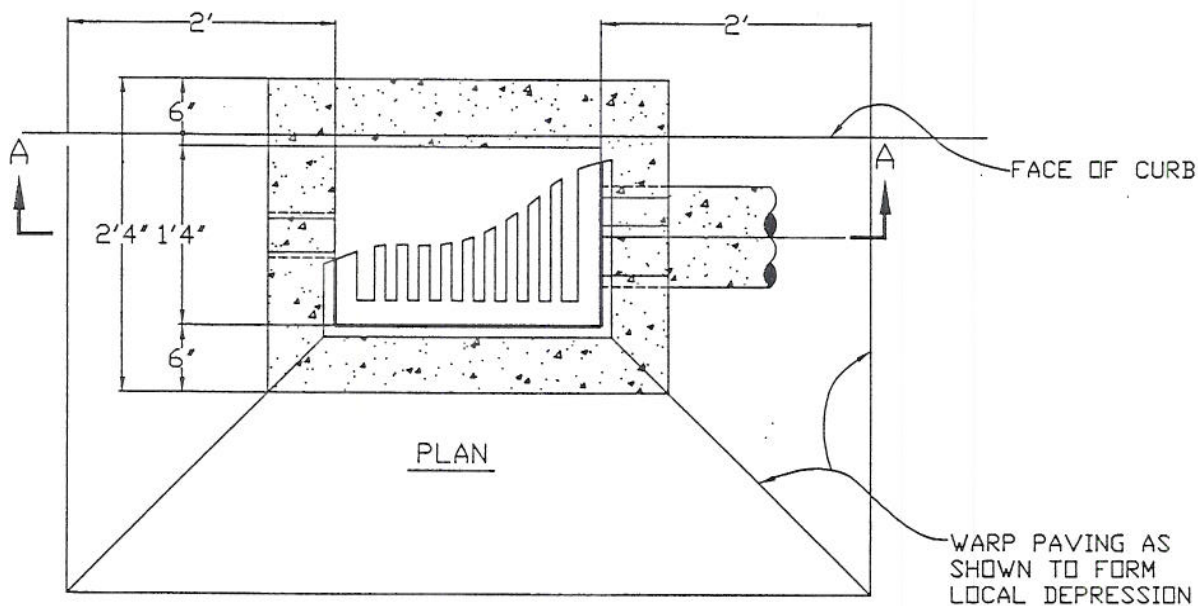

PLAN

NOTES:

1. Pipes can be placed in any wall, maximum pipe size-18"
2. Station shown on project plans is to centerline of C.B.
3. All concrete shall be 3300 psi per section 440 of the Standard Specifications of the Oregon State Highway Division. (1991 Ed.)
4. Drains shall be 4" concrete drain tile.
5. To construct cleanout, replace grate with 15.5"x-23.5" steel plate 3/4" thick. Drill one 1" dia. lift hole near one end plate.
6. For location, pipe size, and elevation, see project plans.

Approved Jerry R. Snipes 6-30-98
 County Engineer Date

STANDARD CATCHBASIN DETAILS
 TYPE 1 CATCHBASIN
 AND CLEANOUT

POLK COUNTY PUBLIC WORKS
 751 SW CLAY ST.
 DALLAS, OR 97338
 503-623-9287

DRAWN BY: FCL CHECKED BY: TRS
 DATE: June 1998 DRAWING NO: 0031A

No	DESCRIPTION	DATE	BY	Appr

REVISION

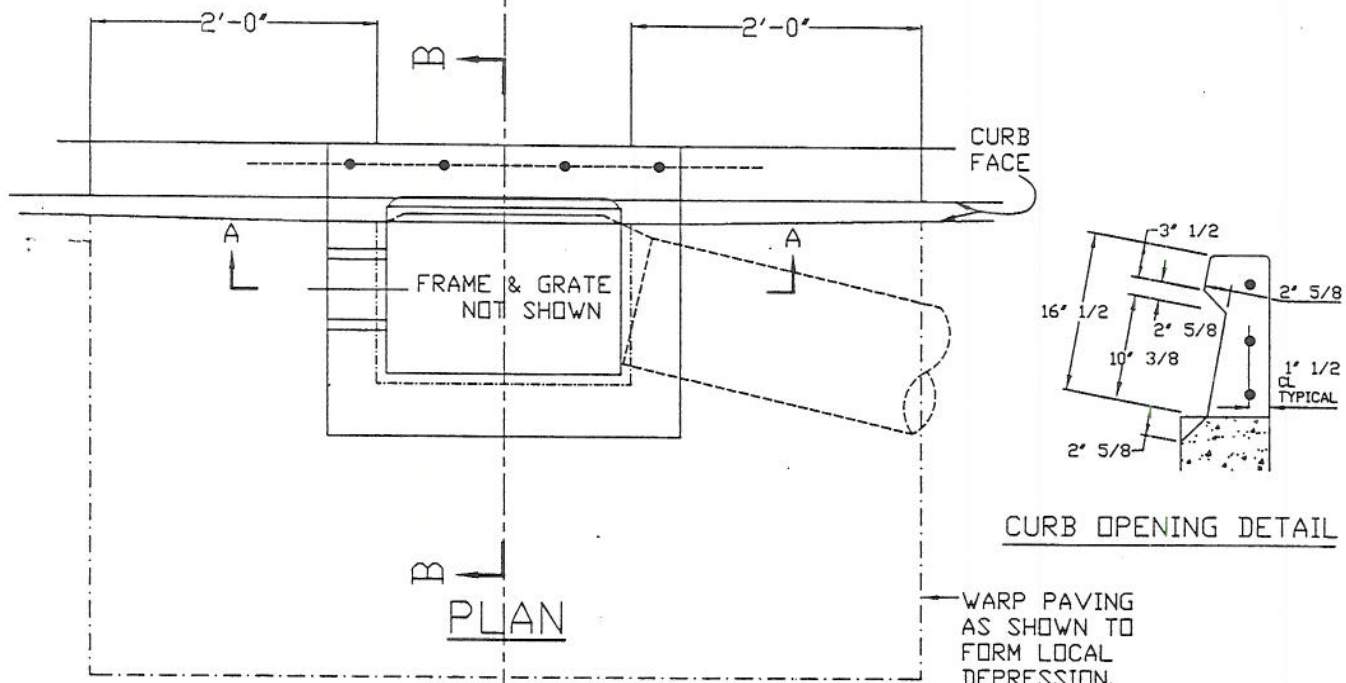

CURB OPENING DETAIL

WARP PAVING AS SHOWN TO FORM LOCAL DEPRESSION. (DEPTH-1')

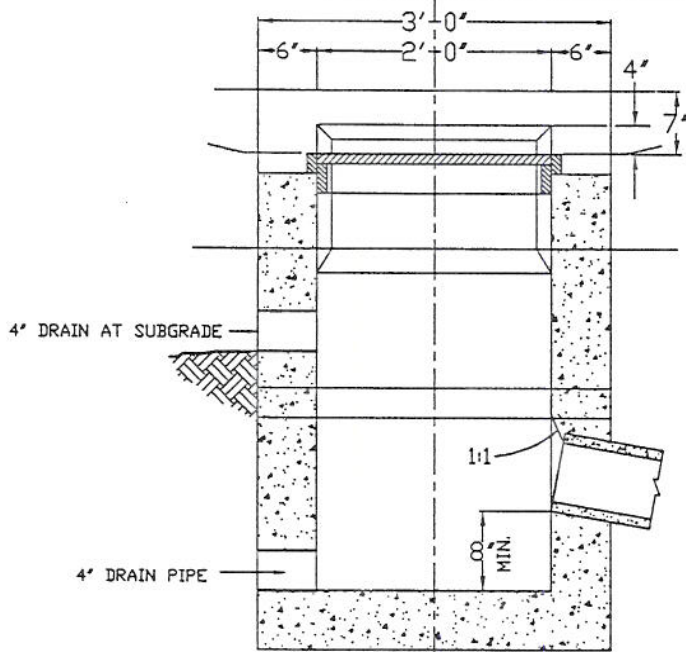

SECTION A-A

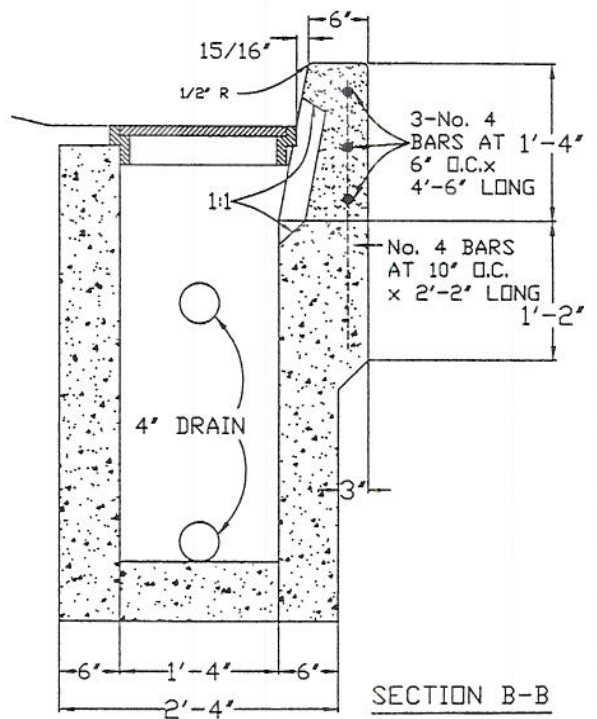

SECTION B-B

NOTES

1. Drains shall be 4" concrete drain tile.
2. For location, pipe size, and elevation, see project plans.
3. Pipes can be placed in any wall. Maximum pipe size 18".
4. Station shown on project plan is to centerline of catch basin.

Approved Jerry R. Snyder 6-30-98
County Engineer Date

STANDARD CATCHBASIN DETAILS
TYPE 2 (SIDE INLET) CATCHBASIN

POLK COUNTY PUBLIC WORKS
751 SW CLAY ST.
DALLAS, OR 97338
503-623-9287

No	DESCRIPTION	DATE	BY	Appr

REVISION

DRAWN BY: FCL

CHECKED BY: TRS

DATE: June 1998

DRAWING NO: 0031B

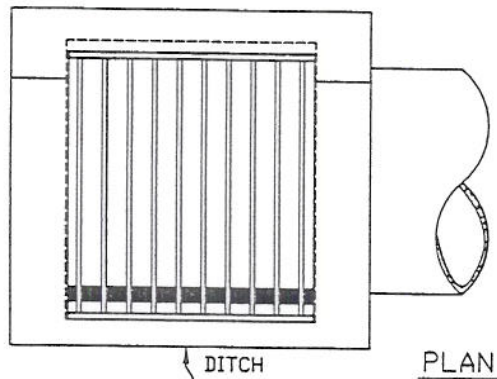

PLAN

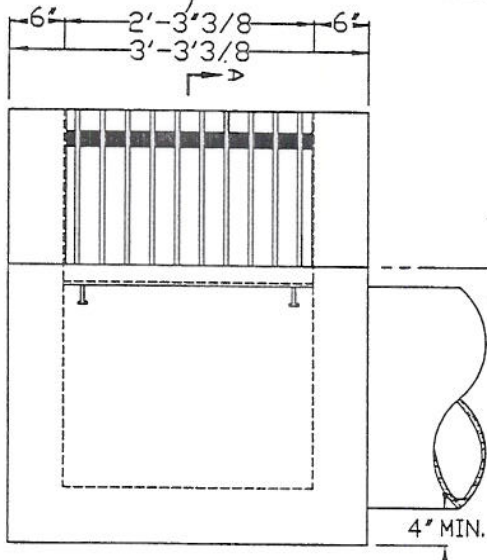

ELEVATION

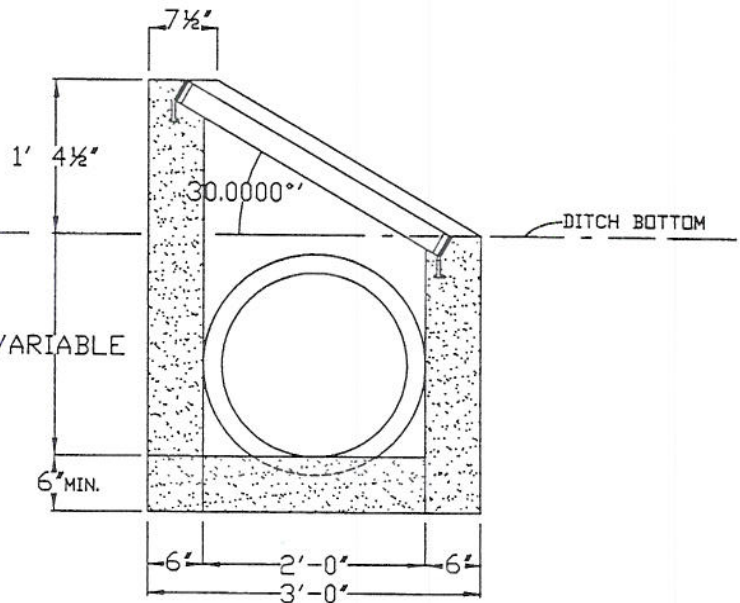

SECTION A-A

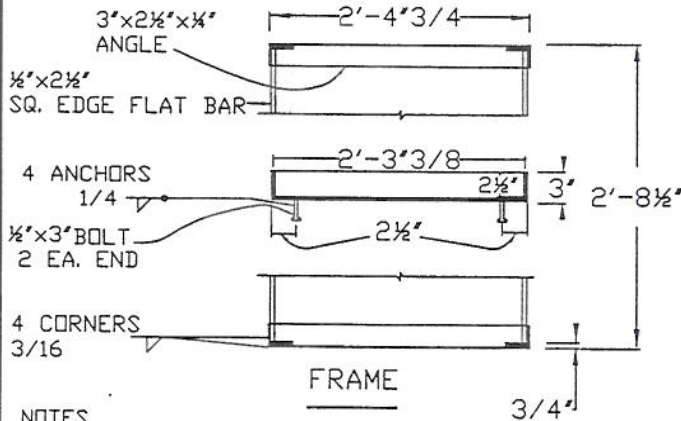

FRAME

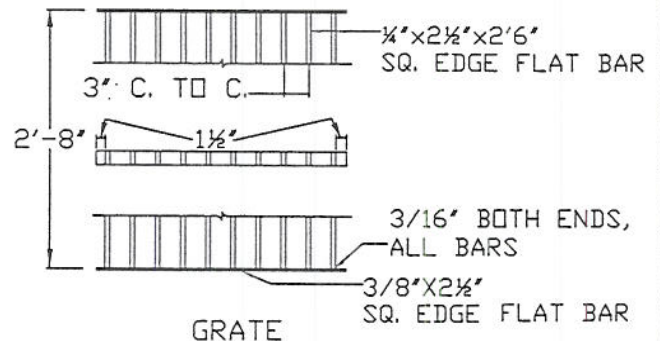

GRATE

NOTES

1. For location, pipe size, and elevation, see project plans.
2. Catch basin may be built with or without a sump, as directed by Engineer.
3. Frame and grate material shall be steel (A.S.T.M. A-36) and be galvanized in accordance with A.S.T.M. A-123.

Approved *Tony R. Snyder* 6-30-98
County Engineer Date

STANDARD CATCHBASIN
DETAILS: TYPE 3 CATCHBASIN, FRAME & GRATE

POLK COUNTY PUBLIC WORKS
751 SW CLAY ST.
DALLAS, OR 97338
503-623-9287

DRAWN BY: FCL CHECKED BY: TRS
DATE: June 1998 DRAWING NO: 0031C

No	DESCRIPTION	DATE	BY	Appr
REVISION				

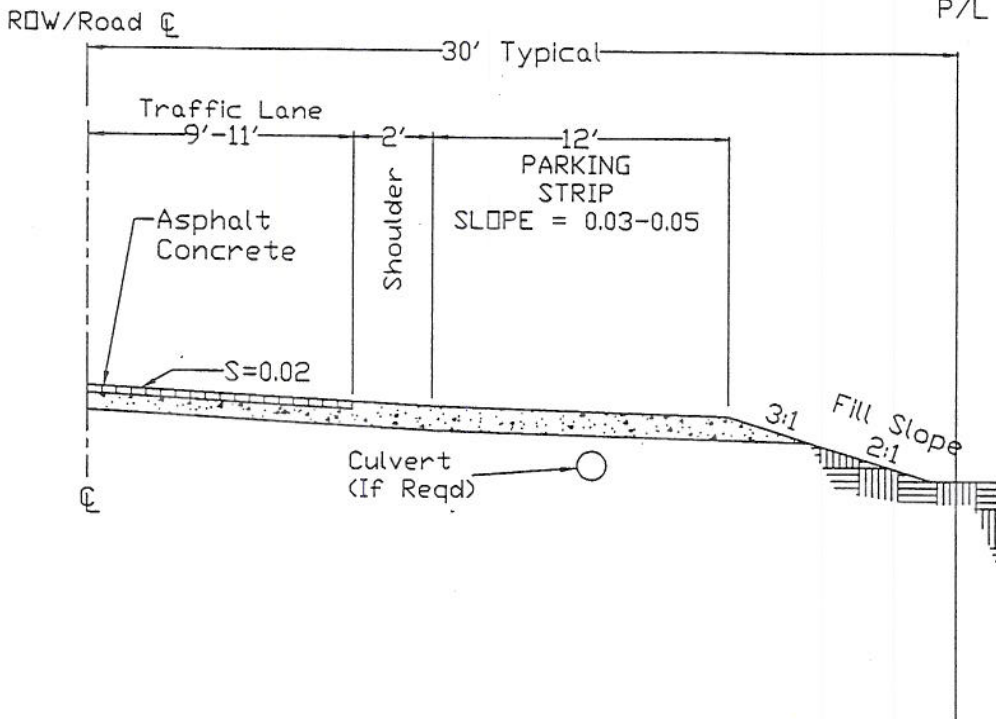

Notes:

1. Materials and construction shall conform to the Polk County Road Standards, ODOT Standard Specifications for Highway Construction and the appropriate details may be used to supplement these standards as approved by the Public Works Director.
2. Shy distance is the minimum offset distance from the edge of traffic lane to a parked vehicle. The shy distance shall be a minimum of 6'.
3. The depth of rock shall be determined by the County Engineer for the anticipated vehicle type and soil type. For parking strips on local roads, the minimum depth of gravel shall be 8" of 1"-0 crushed aggregate.

Approved Tommy R. Snipes 6-30-98
 County Engineer Date

TYPICAL PARKING STRIP	
POLK COUNTY PUBLIC WORKS 751 SW CLAY ST. DALLAS, OR 97338 503-623-9287	
DRAWN BY: FCL	CHECKED BY: TRS
DATE: June 1998	DRAWING NO: 0033

No	DESCRIPTION	DATE	BY	Appr
REVISION				

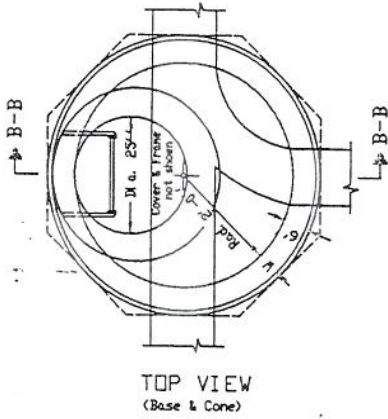

TOP VIEW
(Base & Cone)

NOTE: Shape bottom of manhole as shown on "Plan of Base" and Section A-A for "Base, Risers & Cone"

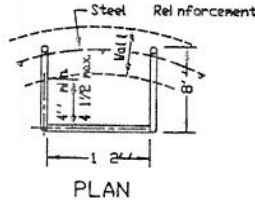

PLAN

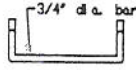

FRONT

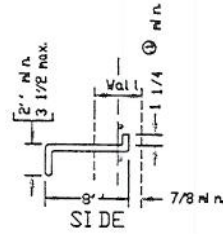

SIDE

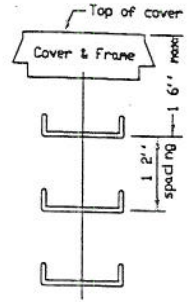

STEPS

(Steps may be substituted for ladder)

① Eliminate hook, provided steps will withstand a "pull" force of 1,000 lbs. without loosening.

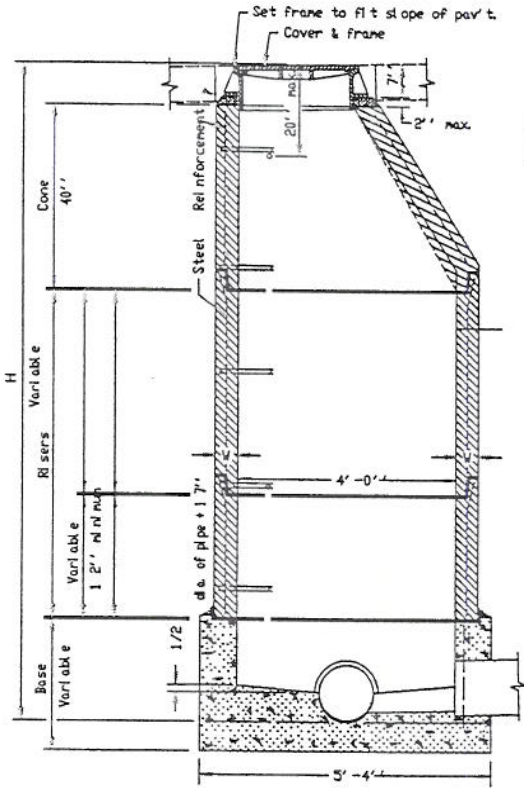

SECTION A-A
(Base, Risers & Cone)

3/4 precast filler, (in conc. pav't., gutter, or walk only) to extend through thickness of conc.

Minimum length if laterals or connections are inserted outside

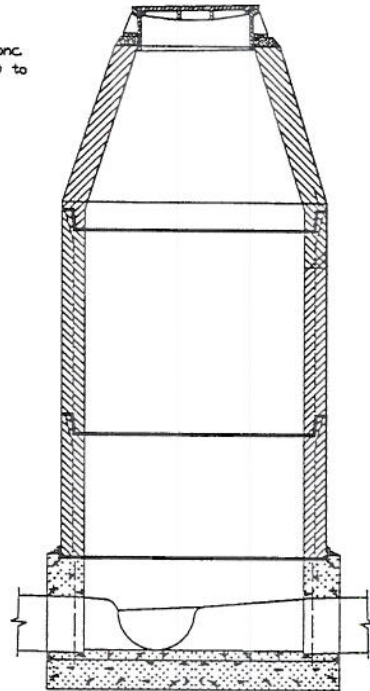

SECTION B-B

Minimum length of any section in which laterals or connections are inserted outside of pipe + 1 7/8" + tongue.

Make holes for connections from catch basins in precast section. Set pipes to lines and grades furnished by the engineer. GROUT IN. This work is to be done by the contractor before the precast section is set in place in the manhole. Number of connections varies.

Variable (use only where required) One or more sections, 1 2' long or over

NOTES

1. Precast barrel, cone, and extension rings shall be reinforced concrete manhole sections conforming to ASTM C 478, AASHTO M199.
2. For manhole with "H" less than 4'-0" see project plans.
3. Inside joints shall not exceed 3/8" in thickness.
4. Form channels in manhole case as shown.
5. For location, pipe size, and elevation, see project plans, maximum pipe size - 21".
6. Plywood form manhole base.
7. Concrete for base shall be class 3300 1-1/2" per section 504 of the standard specifications of the Oregon State Highway Division.

Approved Tommy R. Smyles 6-30-98
County Engineer Date

STORM DRAIN STANDARD PRECAST MANHOLE

POLK COUNTY PUBLIC WORKS
751 SW CLAY ST.
DALLAS, OR 97338
503-623-9287

NO	DESCRIPTION	DATE	BY	Appr	DRAWN BY: FCL	CHECKED BY: TRS
	REVISION				DATE: June 1998	DRAWING NO: 0037

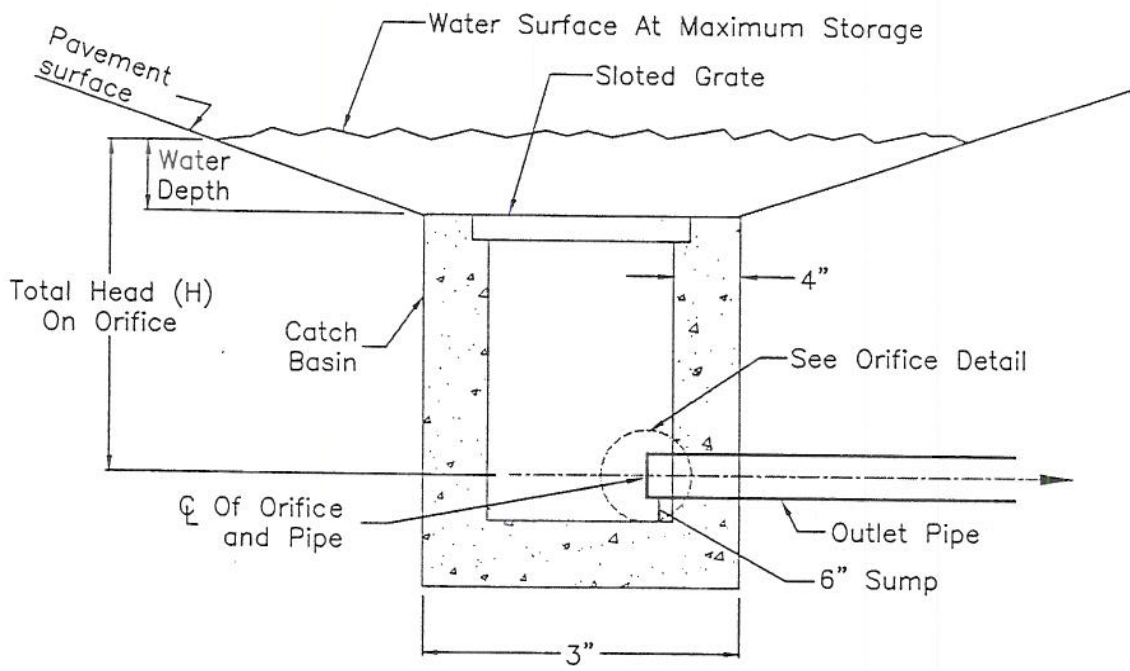

TYPICAL CATCH BASIN DETAIL

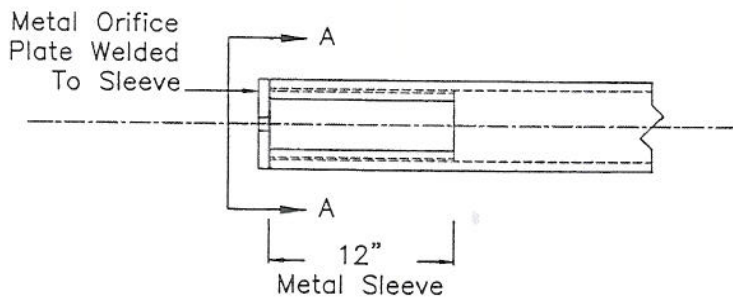

TYPICAL ORIFICE DETAIL

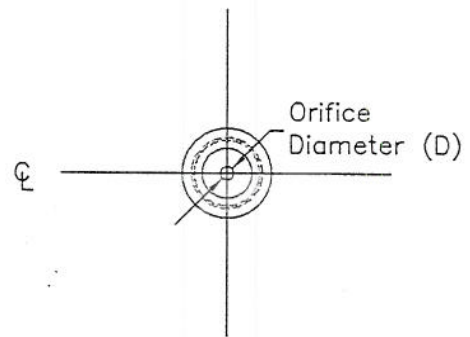

SECTION A-A

Notes:

1. Catch Basin may be round, square or rectangular.

Approved Tommy R. Snyder 6-30-98
 County Engineer Date

STORM WATER DETENTION
 FOR SITES OF 5 ACRES OR LESS

POLK COUNTY PUBLIC WORKS
 751 SW CLAY ST.
 DALLAS, OR 97338
 503-623-9287

DRAWN BY: CDM CHECKED BY: TRS

DATE: June 1998 DRAWING NO: 0038

No	DESCRIPTION	DATE	BY	Appr
	REVISION			

- NOTES: 1) PROVIDE DIRECT DRAINAGE CONTACT BETWEEN BASE ROCK, SUB BASE ROCK & SUBGRADE DRAIN.
 2) LOCATE SUBGRADE DRAIN ON UPHILL SIDE OF ROAD OR AS DIRECTED BY ENGINEER.
 3) SHOW PROPOSED LOCATION ON PLANS.
 4) USE ASTM D-2729 PERFORATED P.V.C.

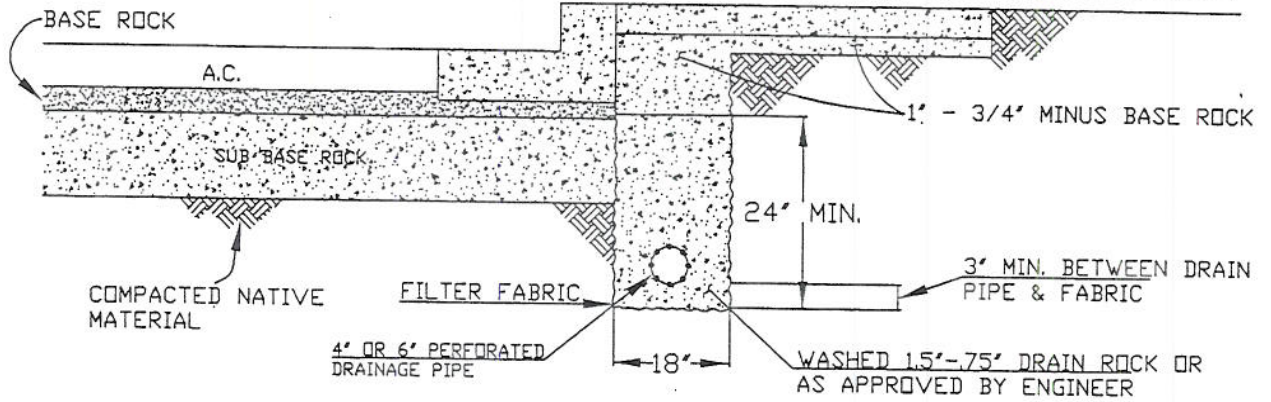

TYPICAL SUBGRADE DRAIN

SPRING CATCHMENT DETAIL

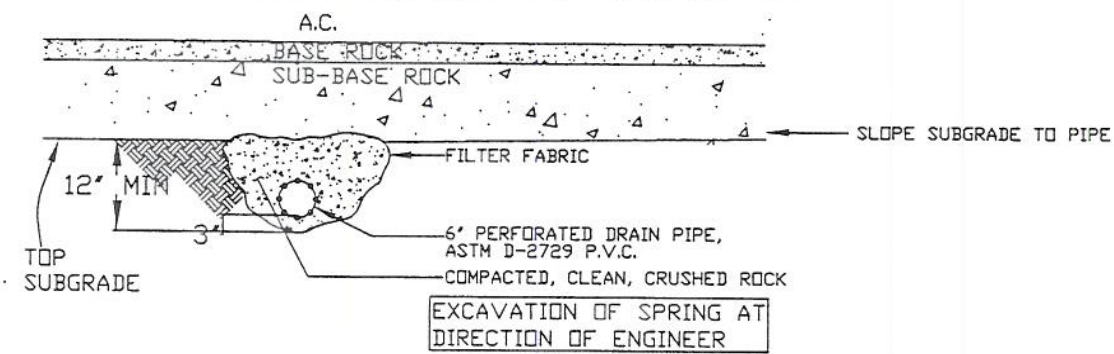
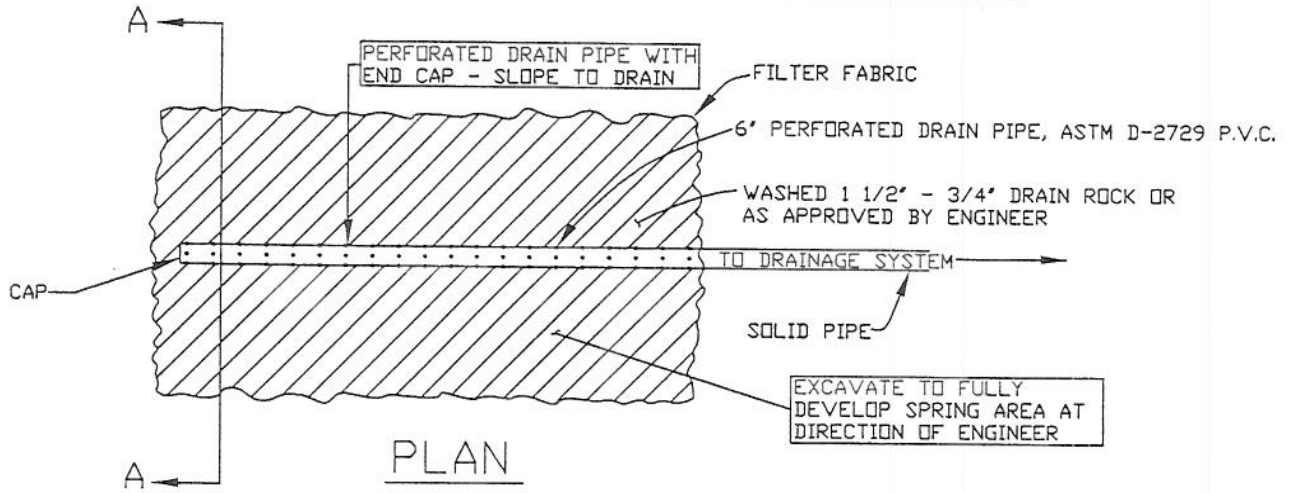

Approved Tony R. Sander 6-30-98
 County Engineer Date

SECTION A-A

SUBGRADE AND SPRING CATCHMENT DRAINS

POLK COUNTY PUBLIC WORKS
 751 SW CLAY ST.
 DALLAS, OR 97338
 503-623-9287

FCL	TRS
June 1998	0039

No	DESCRIPTION	DATE	BY	Appr
REVISION				

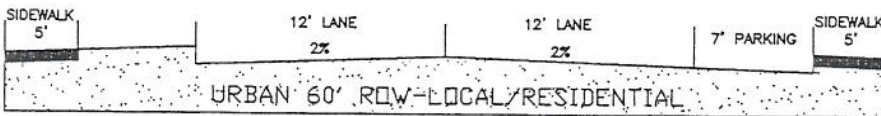
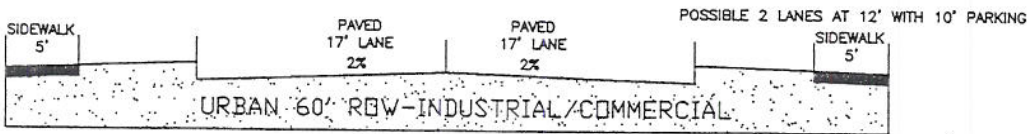
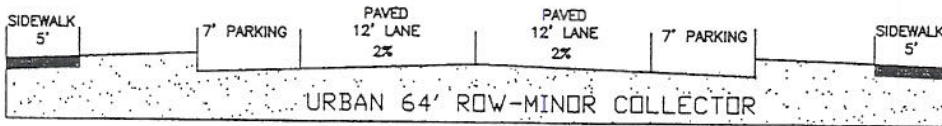
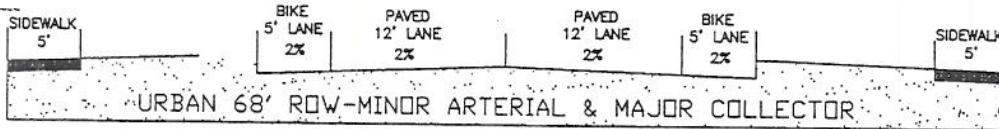
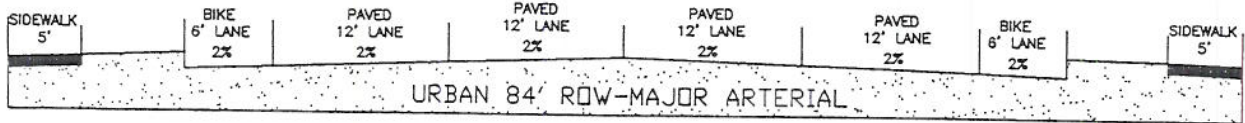

PARKING (EITHER SIDE, BOTH OR NONE)

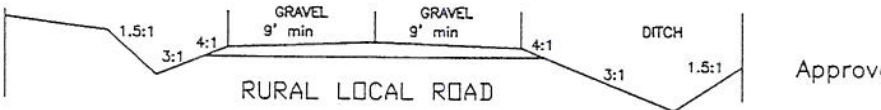
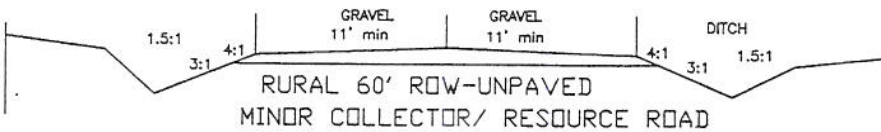
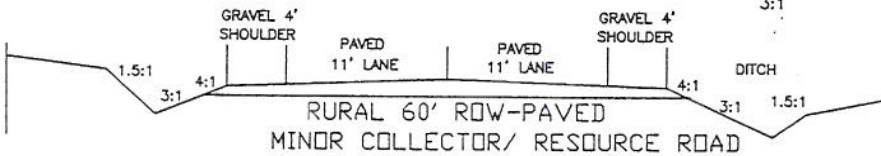
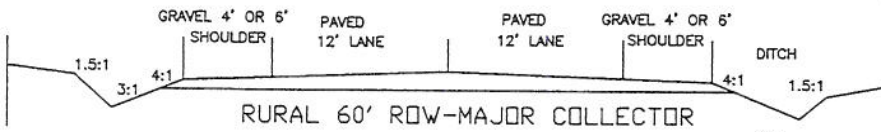
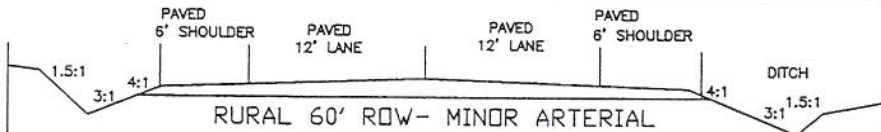

Approved Tony Smyles July 7, 1998
County Engineer Date

TYPICAL ROADWAY SECTIONS

POLK COUNTY PUBLIC WORKS
751 SW CLAY ST.
DALLAS, OR 97338
503-623-9287

DRAWN BY: FCL	CHECKED BY: TRS
DATE: June 1998	DRAWING NO: 0040

No.	DESCRIPTION	DATE	BY	Appr
	REVISION			

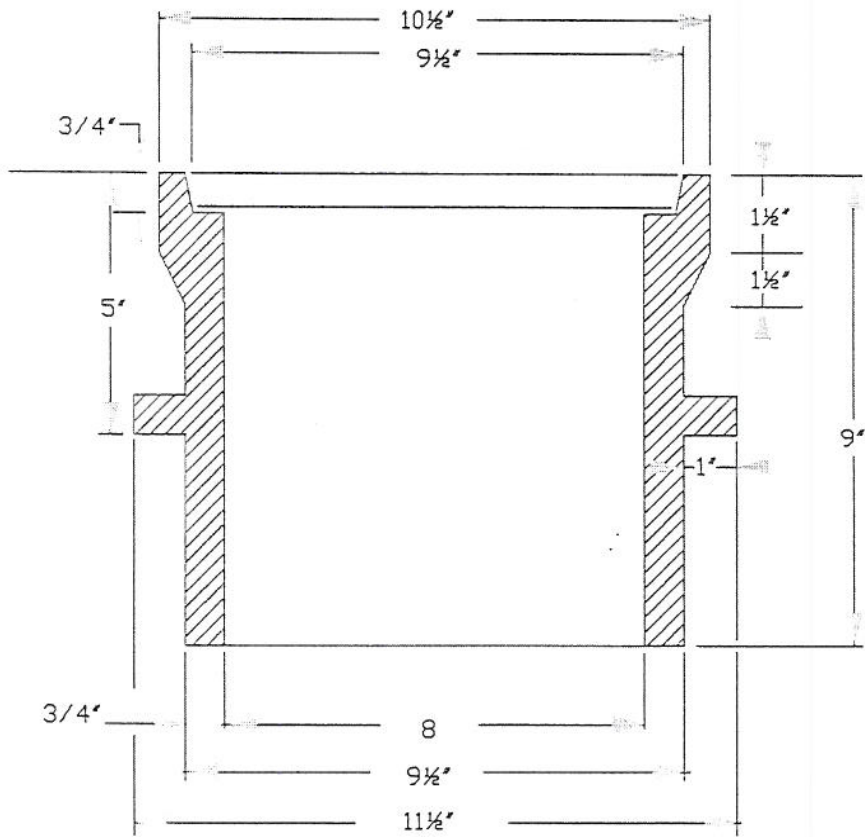
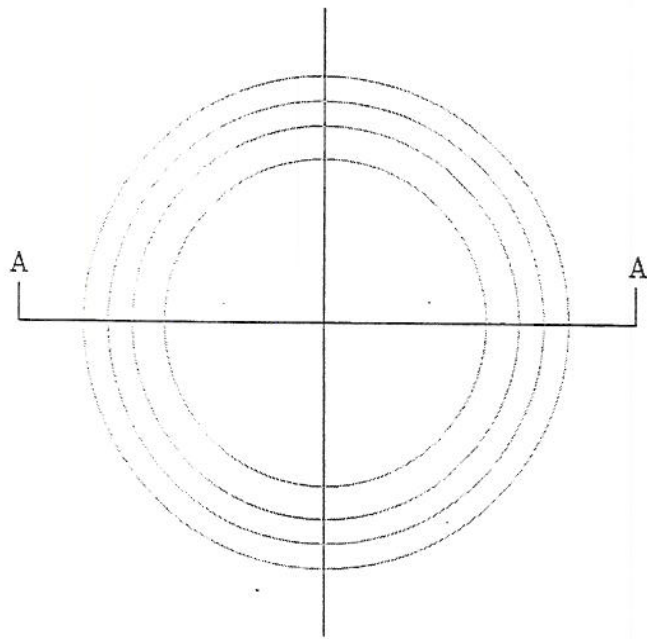

SECTION A-A

Approved Tommy R. Snipes 6-30-98
County Engineer Date

MONUMENT BOX

POLK COUNTY PUBLIC WORKS
751 SW CLAY ST.
DALLAS, OR 97338
503-623-9287

No	DESCRIPTION	DATE	BY	Appr

DRAWN BY: FCL	CHECKED BY: TRS
DATE: June 1998	DRAWING NO: 0041

REVISION

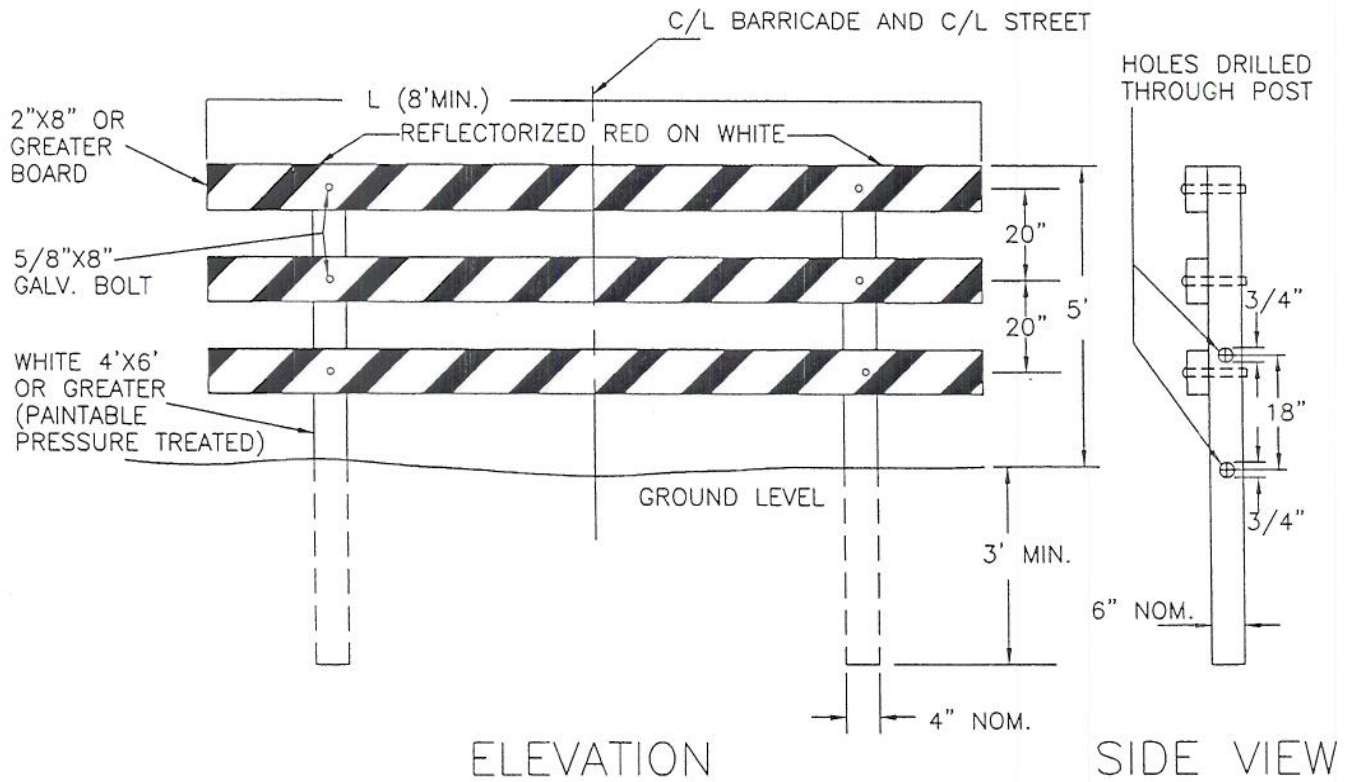

NOTES:

1. REFLECTORIZED SHEETING SHALL BE ENGINEERING GRADE REFLECTIVE SHEETING CONFORMING TO 1991 EDITION OF THE OREGON STATE HIGHWAY DIVISIONS "STANDARD SPECIFICATIONS FOR HIGHWAY CONSTRUCTION SECTION 02910.
2. THE LENGTH OF THE BARRICADE UNIT "L" AND NUMBER AND POSITIONING OF THE UNITS WILL BE SHOWN ON PROJECT PLANS.

Approved Jonny R. Snyder 10-19-00
 County Engineer Date

PERMANENT BARRICADE				
POLK COUNTY PUBLIC WORKS 820 SW ASH ST DALLAS, OR 97338 503-623-9287				
No	DESCRIPTION	DATE	BY	Appr
REVISION				
			DRAWN BY: B.J.L.	CHECKED BY: TRS
			DATE: Sept 2000	DRAWING NO: 0042

**Table 6
Rural Geometric Design Standards**

Road Classification	Traffic Volume (ADT)	Minimum R/W Width ¹	Minimum Pavement Width (if required)	Travel Lane Width	Minimum Shoulder Width	Minimum Bikeway Width (if required) ³	Shoulder Parking	Terrain Cross Slope ---	Design Speed (MPH) ⁴	Minimum Horizontal Curve Radius	Maximum Degree of Curve	Super (FT/FT) ⁵	Maximum Grade (%) ⁶	Pavement Cross Slope (FT/FT) ⁷	Minimum Stopping Sight Distance	Minimum Passing Sight Distance	Minimum Clear Roadway Width	Design Loading Structural Capacity
Minor Arterial	1500 - 15,000	60 ft.	32 ft.	12 ft.	4 ft. paved 2 ft. gravel	6 ft. shared shoulder	None provided	S < 5%	55	1,061 ft.	5.4	0.06	6	0.02	450-500 ft.	1,950 ft.	32 ft.	HS-20
								5% <= S <= 10%	45	660 ft.	8.7	0.06	8	0.02	325-400 ft.	1,650 ft.		
								S > 10%	35	360 ft.	15	0.06	10	0.02	225-250 ft.	1,300 ft.		
Major Collector	1,500 - 3,000	60 ft.	24 ft.	12 ft.	4-6 ft. gravel	6 ft. shared shoulder	None provided	S < 5%	55	1,061 ft.	5.4	0.06	6	0.02	450-500 ft.	1,950 ft.	30 ft.	HS-20
								5% <= S <= 10%	45	660 ft.	8.7	0.06	8	0.02	325-400 ft.	1,650 ft.		
								S > 10%	35	360 ft.	15	0.06	10	0.02	225-250 ft.	1,300 ft.		
Minor Collector	500 - 1,500	60 ft.	22 ft.	11 ft.	2-4 ft. gravel	None required	None provided	S < 5%	55	1,061 ft.	5.4	0.06	6	0.02	450-500 ft.	1,950 ft.	28 ft.	HS-20
								5% <= S <= 10%	45	660 ft.	8.7	0.06	8	0.02	325-400 ft.	1,650 ft.		
								S > 10%	35	360 ft.	15	0.06	10	0.02	225-250 ft.	1,300 ft.		
Resource Road	0 - 500	60 ft.	18 ft.	9 ft.	2 ft. gravel	None required	None provided	S < 5%	55	1,061 ft.	5.4	0.06	6	0.02	450-500 ft.	1,950 ft.	28 ft.	HS-20
								5% <= S <= 10%	45	660 ft.	8.7	0.06	8	0.02	325-400 ft.	1,650 ft.		
								S > 10%	35	360 ft.	15	0.06	10	0.02	225-250 ft.	1,300 ft.		
Local	0 - 500	60 ft. ²	18 ft.	9 ft.	2 ft. gravel	None required	On shoulder	S < 5%	45	730 ft.	7.9	0.04	7	0.02	325-400 ft.	1,650 ft.	26 ft.	HS-20
								5% <= S <= 10%	35	420 ft.	13.7	0.04	10	0.02	225-250 ft.	1,300 ft.		
								S > 10%	25	203 ft.	28.2	0.04	15	0.02	150 ft.	950 ft.		

¹ Slope easements or additional right-of-way shall be required where construction extends beyond minimum right-of-way.

² A lesser width may be allowed where physical conditions dictate.

³ Roads that are designated as bike routes shall have paved shoulders.

⁴ The design speed shall be determined or approved by the Public Works Director.

⁵ For open roadways, superelevation may be increased as per Section XI (L)(5). For superelevation values greater than .06 see Table 11.

⁶ A greater maximum grade may be allowed where topography dictates.

⁷ The cross slope on gravel roads is .03-.05 ft/ft.

Table 7
Urban Geometric Design Standards

Road Classification	Traffic Volume (ADT)	Minimum R/W Width	Minimum Pavement Width (if required)	Travel Lane Width	Travel Lanes	Curb & Gutter	Minimum Concrete Sidewalk Width	Minimum Bike Lane Width	Parking	Design Speed (MPH)	Minimum Horizontal Curve Radius	Maximum Degree of Curve	Maximum Super (FT/FT)	Maximum Grade (%)	Pavement Cross Slope (FT/FT)	Minimum Stopping Sight Distance	Minimum Access Spacing	Design Loading Structural Capacity
Major Arterial	15,000+	84 ft.	60 ft.	12 ft.	4	Type A ¹	5 ft. both sides	6 ft. both sides	Prohibited	35	420 ft.	13.7	0.04	5	0.02	225-250	400 ft.	HS-25
Minor Arterial	6,000 - 15,000	68 ft.	34 ft.	12 ft.	2	Type A ¹	5 ft. both sides	5 ft. both sides	Prohibited	35	420 ft.	13.7	0.04	5	0.02	225-250	400 ft.	HS-25
Major Collector	3,000 - 6,000	68 ft.	34 ft.	12 ft.	2	Type A ¹	5 ft. both sides	5 ft. both sides	Prohibited	35 ft.	420 ft.	13.7	0.04	8	0.02	225-250	150 ft.	HS-25
Minor Collector	2,000 - 3,000	64 ft.	38 ft.	12 ft.	2	Type A ¹	5 ft. both sides	None required	7 ft. both sides	35	420 ft.	13.7	0.04	12	0.02	225-250	150 ft.	HS-25
Industrial/Commercial	0 - 2,000	60 ft.	34 ft.	12 ft.	2	Type A ¹	5 ft. both sides	None required	None May be required	25	225 ft.	25.4	Normal crown	6	0.02	150	None provided	HS-25
Local/Residential	0 - 2,000	60 ft.	34 ft.	10 ft.	2	Type A ¹	On shoulder 5 ft. both sides	None required	7 ft. both sides	25	225 ft.	25.4	Normal crown	12	0.02	150 ft.	1 per tax lot	HS-25

¹Type C Curb may be required.

Table 8
Cul-de-Sac Design Standards

Road Classification	Transition Radius Into Turnaround	R/W Width Entering Turnaround ¹	Pavement Radius at Turnaround	Pavement Width Entering Turnaround	Shoulder	Sidewalk	Curb	Parking
Rural	25 ft.	60 ft.	40 ft.	22 ft.	2 ft. gravel shoulder	None required	None required	None required
Urban	25 ft.	60 ft.	40 ft.	34 ft.	None required	5 ft. both sides <u>continuous</u>	Type A ²	Both sides <u>Continuous</u>
Industrial/Commercial	30 ft.	60 ft.	45 ft.	34 ft.	None required	5 ft. both sides <u>continuous</u>	Type A ²	None required

¹ Right-of-way radius within transition or bulb shall be sufficient to maintain at least the same right-of-way to edge of traffic lane as in the adjacent section of road, unless otherwise approved by the Public Works Director.

² Type C curb may be required.